

# VANS RV14

## G-STRV



# ELECTRICAL REFERENCE MANUAL



**VANS RV14 G-STRV**  
Electrical Reference Manual

## REVISION SUMMARY

Number	Date	Revision Details	Name
1	Dec 22	First Draft	Steve Hicks



**VANS RV14 G-STRV**  
Electrical Reference Manual

# INDEX

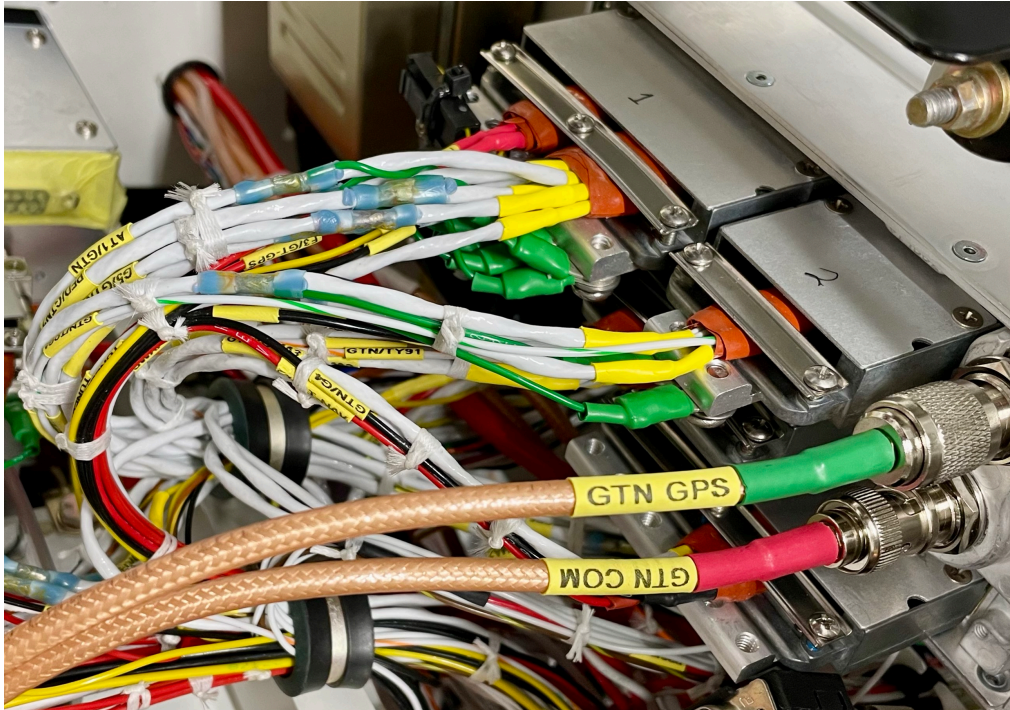

<b>COVER PAGE</b>		<b>i</b>
<b>REVISION SUMMARY</b>		<b>ii</b>
<b>INDEX</b>		<b>iii</b>
<b>INTRODUCTION</b>		<b>iv</b>
<b>KEY</b>		<b>v</b>
<b>SECTION 1</b>	<b>POWER DISTRIBUTION</b>	<b>1 - 1</b>
<b>SECTION 2</b>	<b>AIRFRAME HARNESSSES</b>	<b>2 - 1</b>
<b>SECTION 3</b>	<b>AVIONICS</b>	<b>3 - 1</b>



**VANS RV14 G-STRV**  
Electrical Reference Manual

## INTRODUCTION

This Electrical Reference Manual is only applicable to Vans RV14 G-STRV, and accurately documents every wire in the aeroplane.

It is designed to be read electronically, when full use can be made of links to aid navigation. Clicking or touching the G-STRV logo on the top left of each page provides access to the main index. Clicking or touching the page title box on the top right of each page navigates back to the the current section index. Each index entry provides a link to the respective topic.

A linked main index is also available in your PDF viewer “Table of Contents”.

Steve Hicks & Tim Nicholas  
G-STRV Builders



**VANS RV14 G-STRV**  
Electrical Reference Manual

# KEY

## Connectors

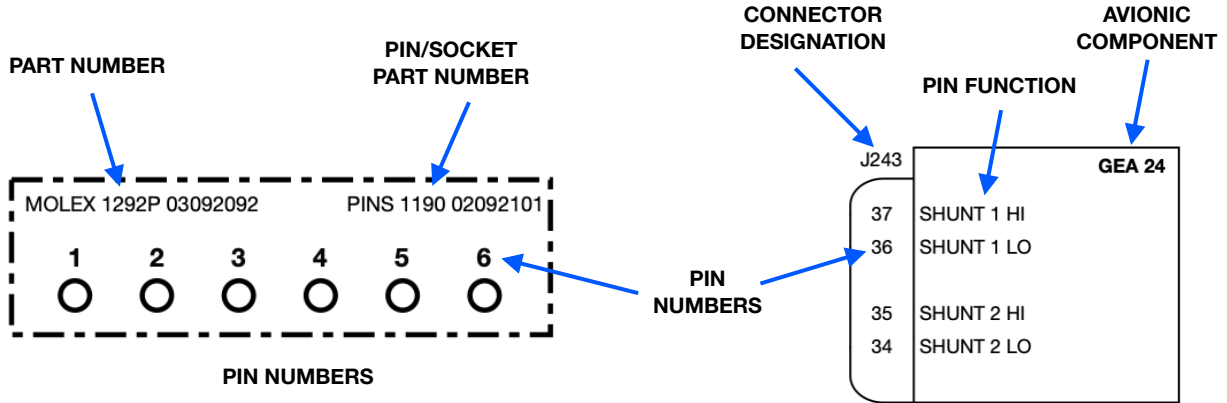

## Wires

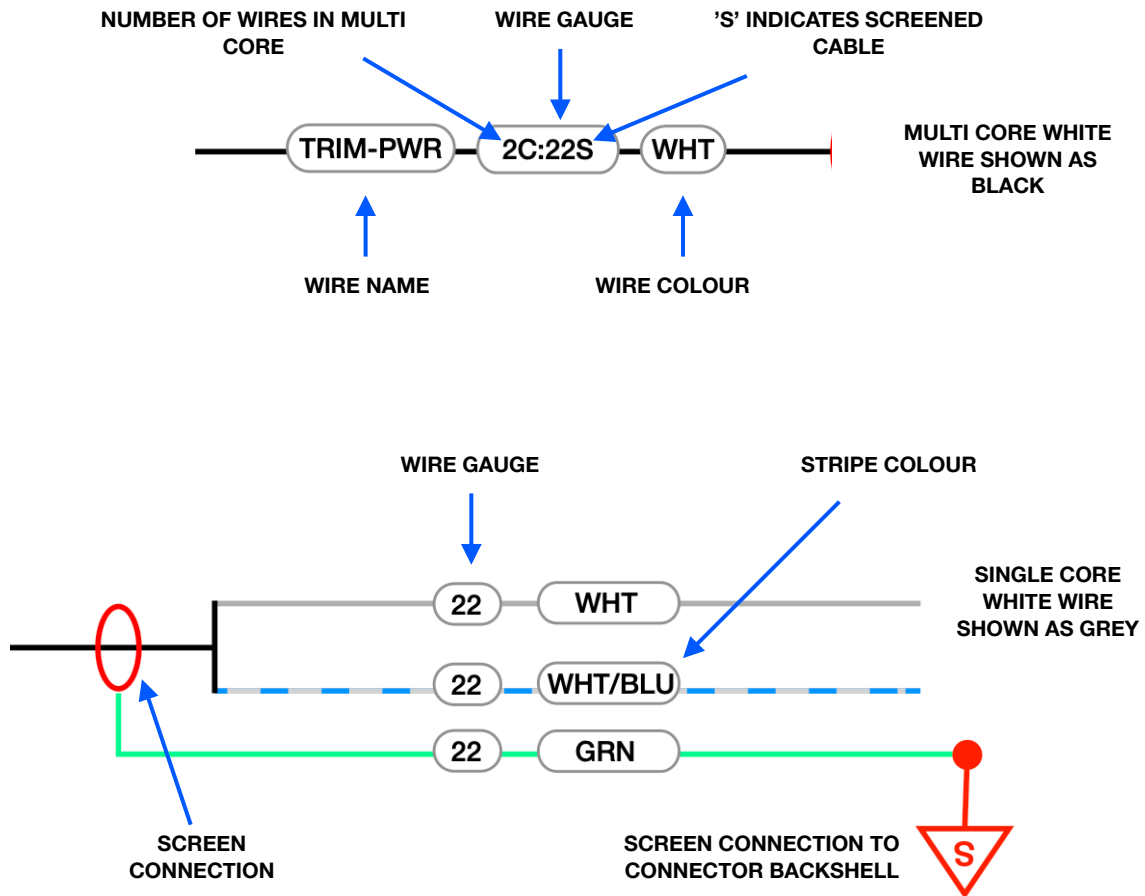



**VANS RV14 G-STRV**  
Electrical Reference Manual

## SECTION 1 - POWER DISTRIBUTION

### Index

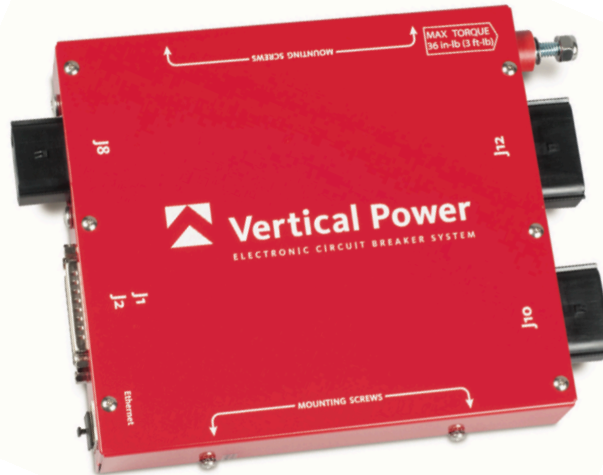

<b>PRIMARY POWER DISTRIBUTION</b>	<b>1 - 2</b>
<b>ELECTRICAL SCHEMATIC</b>	<b>1 - 3</b>
<b>PPS - PRIMARY POWER SUPPLY</b>	<b>1 - 4</b>
<b>VPX J1 and J8</b>	<b>1 - 5</b>
<b>VPX J2</b>	<b>1 - 6</b>
<b>VPX J10</b>	<b>1 - 7</b>
<b>VPX J12</b>	<b>1 - 8</b>
<b>BUS C</b>	<b>1 - 9</b>
<b>IBBS</b>	<b>1 - 10</b>
<b>LR4D VOLTAGE REGULATOR</b>	<b>1 - 11</b>
<b>ROCKER SWITCHES</b>	<b>1 - 12</b>
<b>TOGGLE SWITCHES</b>	<b>1 - 13</b>
<b>LOWER PANEL</b>	<b>1 - 14</b>
<b>GROUND BLOCK</b>	<b>1 - 15</b>



**VANS RV14 G-STRV**  
Electrical Reference Manual

## SECTION 1 - POWER DISTRIBUTION

### Primary Power Distribution

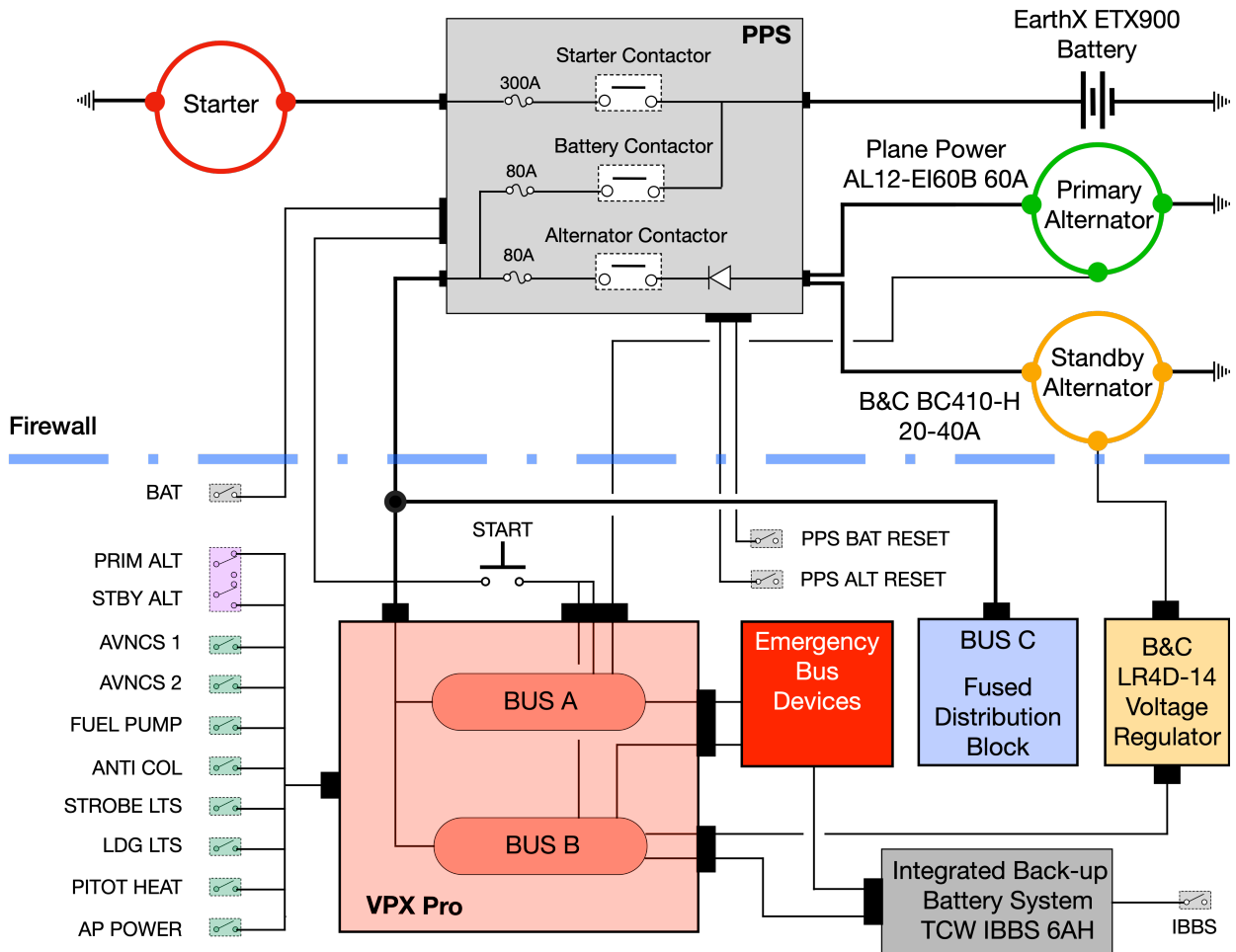

### Power Distribution

A Vertical Power Primary Power System (PPS), situated on the engine side of the firewall, distributes power from the main battery and the alternators to the electrical system. It also provides power to the starter motor when the start button is pressed, as well as providing electrical system protections. Power to energise/de-energise the PPS is controlled by the Battery Master switch. The PPS replaces the need for a battery relay and start solenoid.

Power distribution to individual services is provided by 3 busbars, (A, B and C). Buses A and B are contained within the Vertical Power VPX Pro electronic circuit breaker device (VPX). The VPX is a compact solid state unit with programmable circuit breaker settings. VPX status and settings can be viewed and controlled via a page on the PFD. Bus C is a separate fused distribution block. Buses A, B and C are energised via the PPS whenever the Battery Master is ON. All buses are located in the avionics compartment, accessible through two hatches forward of the canopy.

In the event of a complete power failure, a back up battery, (TCW IBBS rated at 6Ah), will automatically come on line to power essential items on the Emergency Bus for approximately 45 minutes.



**VANS RV14 G-STRV**  
Electrical Reference Manual

**SECTION 1 - POWER DISTRIBUTION**

**Electrical Schematic**

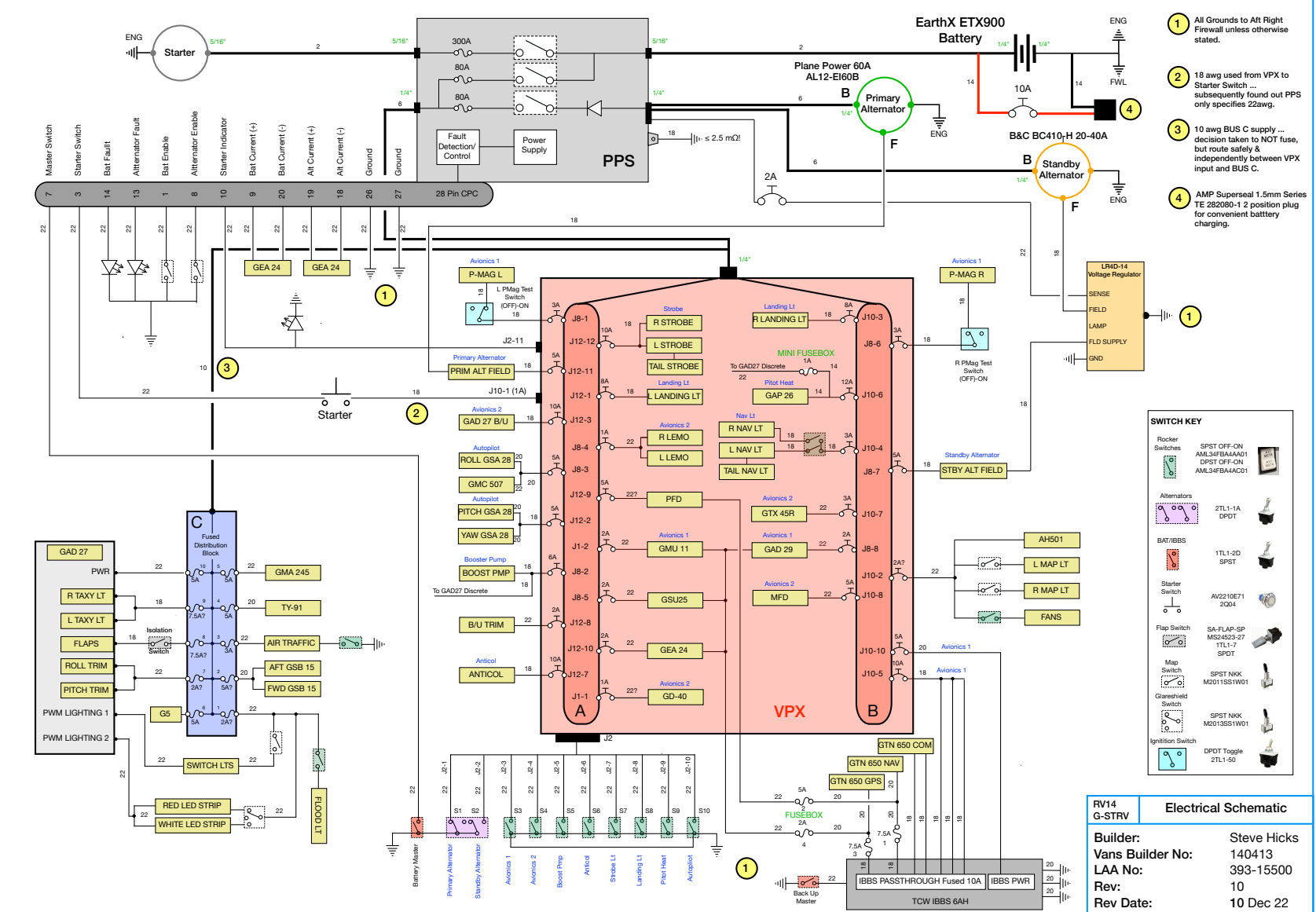

- 1 All Grounds to Aft Right Firewall unless otherwise stated.
- 2 18 awg used from VPX to Starter Switch ... subsequently found out PPS only specifies 22awg.
- 3 10 awg BUS C supply ... decision taken to NOT fuse, but route safely & independently between VPX input and BUS C.
- 4 AMP Supersnel 1.5mm Series TE 282080-1 2 position plug for convenient battery charging.

**SWITCH KEY**

	Rocker Switches	SPST OFF-ON AML3FB4AA01 DPST OFF-ON AML34FB4ACD1	
	Alternators	2TL1-1A DPDT	
	BAT/IBBS	1TL1-2D SPST	
	Starter Switch	AV2210E71 20A4	
	Flap Switch	SA-FLAP-SP MS24523-27 1TL1-7 SPDT	
	Map Switch	SPST NKK M2011SS1W01	
	Glassfield Switch	SPST NKK M2011SS1W01	
	Ignition Switch	DPDT Toggle 2TL1-50	

<b>RV14 G-STRV</b>	<b>Electrical Schematic</b>
<b>Builder:</b>	Steve Hicks
<b>Vans Builder No:</b>	140413
<b>LAA No:</b>	393-15500
<b>Rev:</b>	10
<b>Rev Date:</b>	10 Dec 22



**VANS RV14 G-STRV**  
Electrical Reference Manual

# SECTION 1 - POWER DISTRIBUTION

## PPS - Primary Power Supply

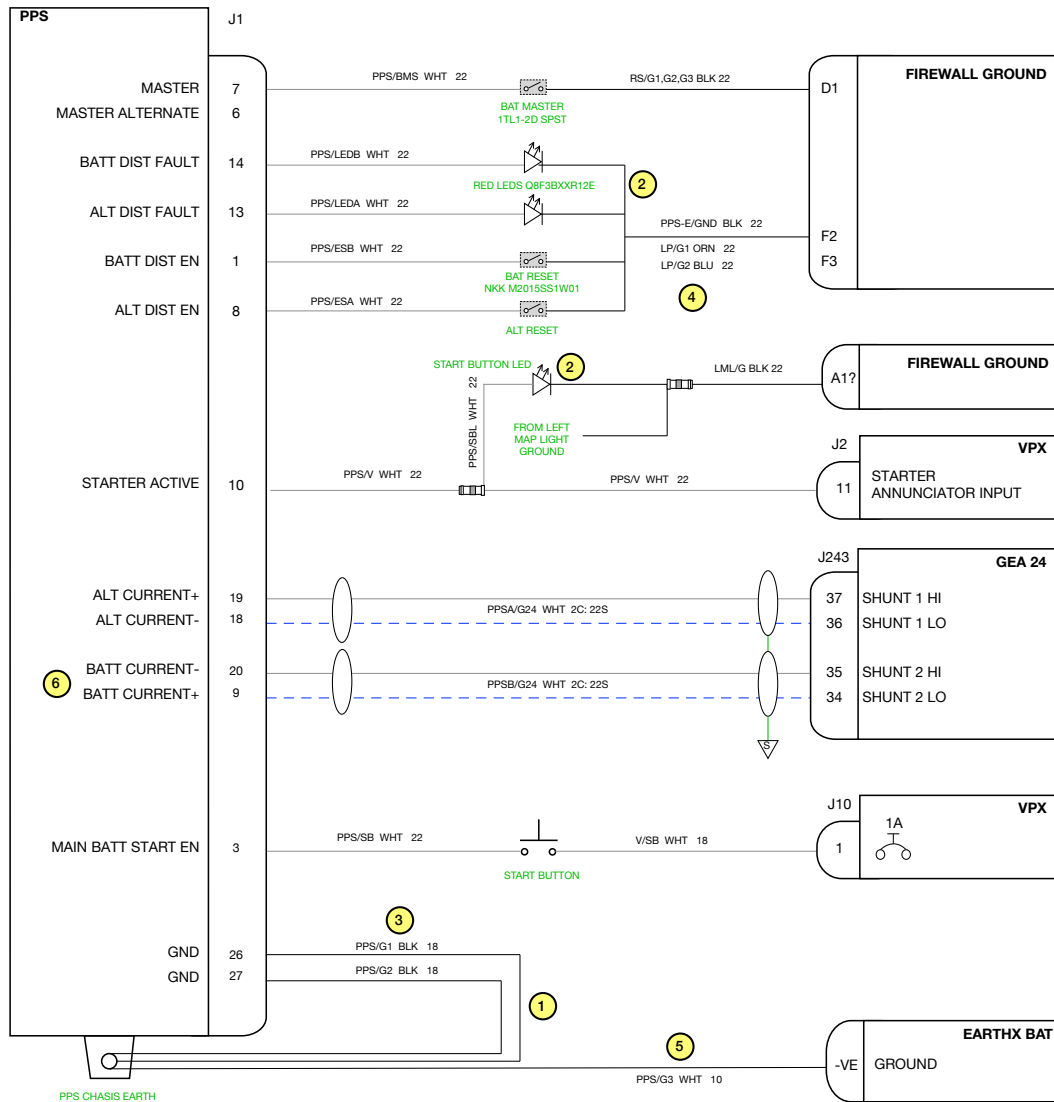

- 1 Maximum wire length with specified 22 awg: 24" Trying to achieve < 2.5 mOhm resistance according to Vertical Power?
- 2 Maximum 10mA
- 3 Used 18 awg to ensure resistance path to battery via PPS/G3 is as low as possible.
- 4 Alternate ground paths - see Lower Panel Schematic
- 5 Used 10 awg to ensure < 2.5 mOhm resistance over 27 ins
- 6 PPS Bat Current+ needs to be connected to GEA24 SHUNT 2 LO for Bat Charge to show as a +ve on G3X, and discharge as a -ve.

	J1 Connector
Positions	28
Contact size	20 gauge
Mating connector	206039-1
Backshell, straight	206070-8
Backshell, right-angle	1546349-2
Crimp Contacts, stamped	1-66506-0
Crimp Contacts, machined	205089-1

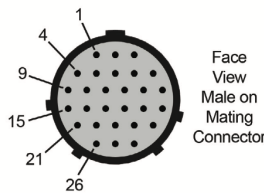

RV14 G-STRV	PPS
Builder:	Steve Hicks
Vans Builder No:	140413
LAA No:	393-15500
Rev:	As Built
Rev Date:	22 Aug 2022



VANS RV14 G-STRV  
Electrical Reference Manual

SECTION 1 - POWER DISTRIBUTION

VPX - J1 and J8

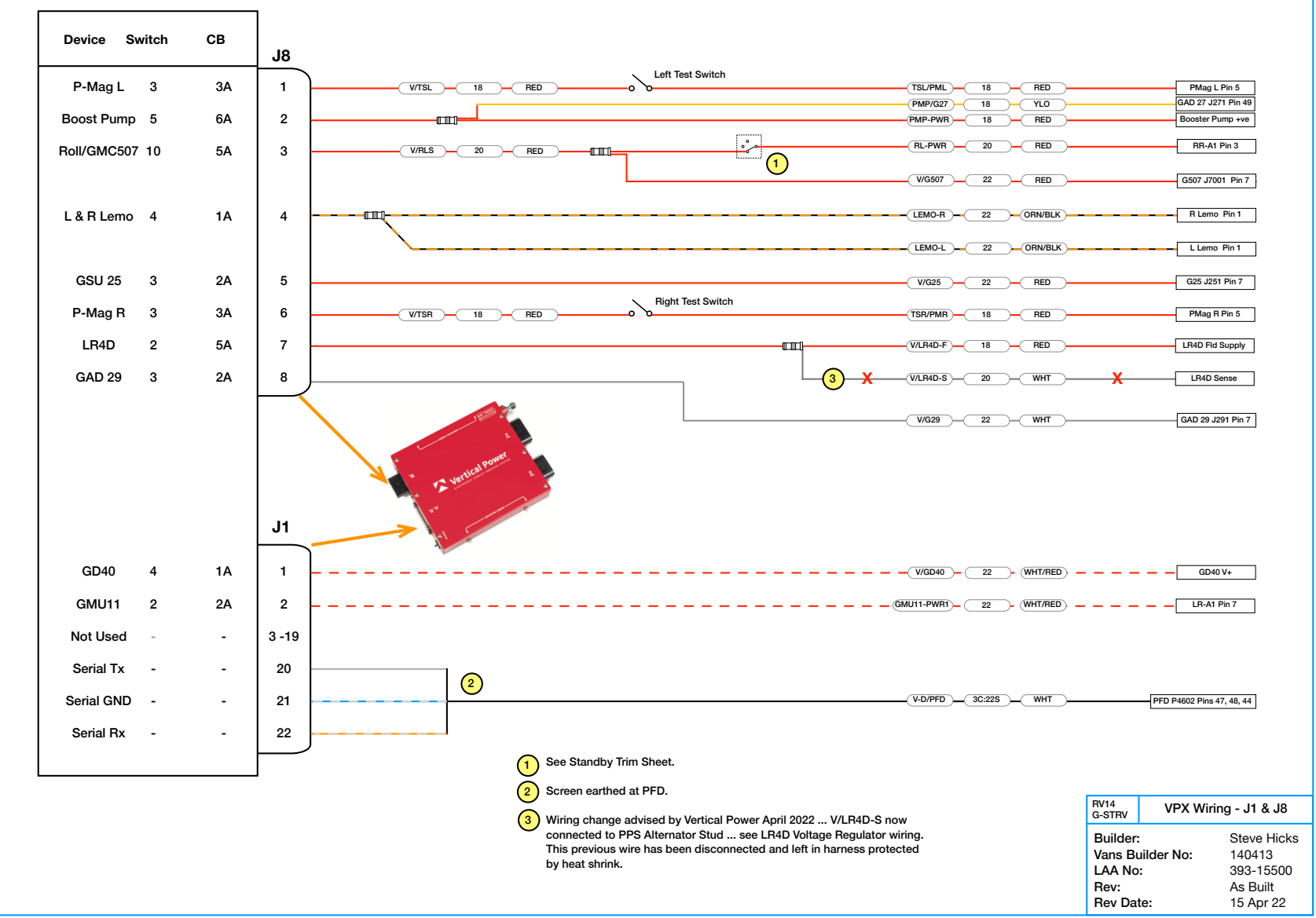



**VANS RV14 G-STRV**  
Electrical Reference Manual

# SECTION 1 - POWER DISTRIBUTION

VPX - J2

① Redundant path for switch earths.

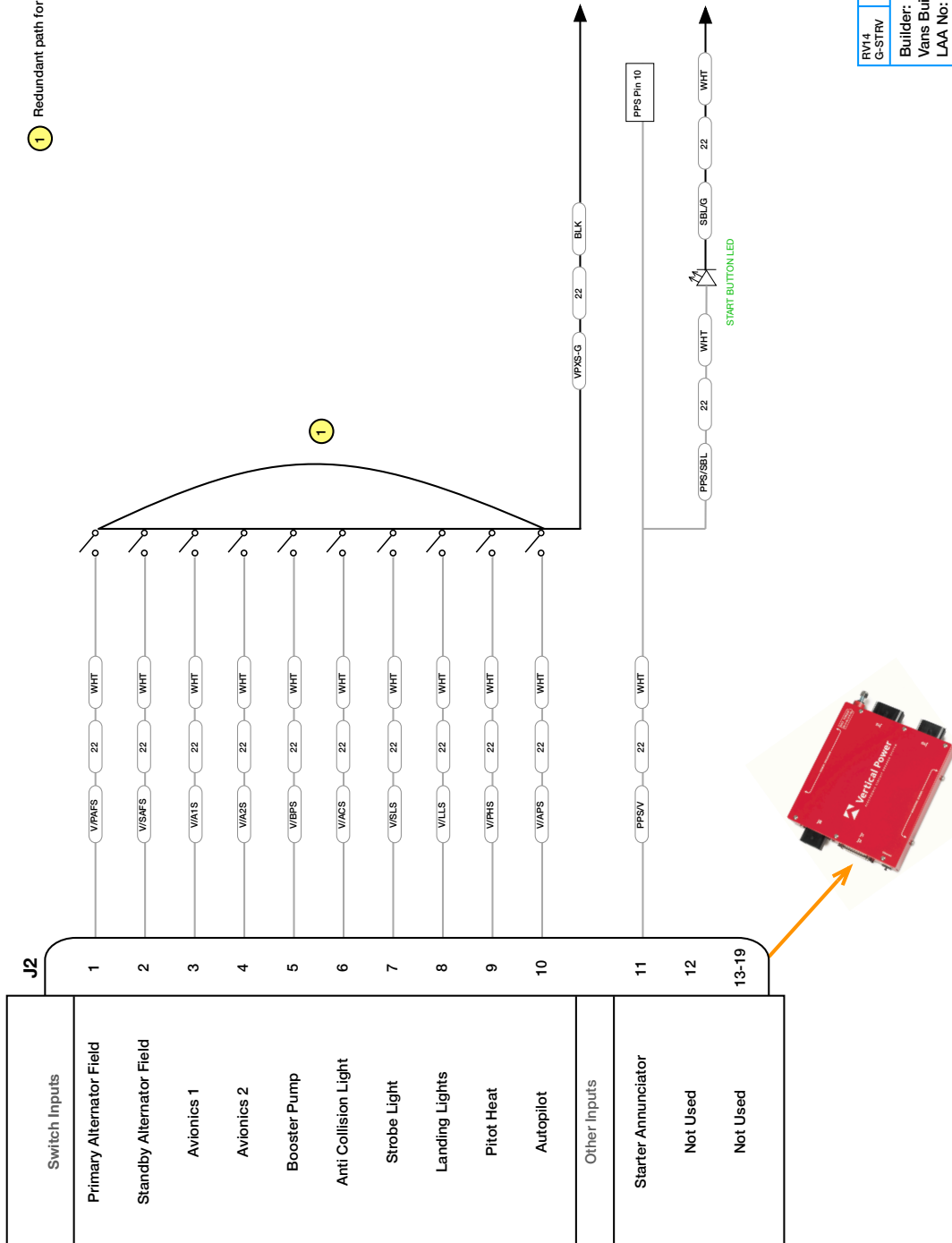

RV14 G-STRV	VPX Wiring - J2
Builder:	Steve Hicks
Vans Builder No:	140413
LAA No:	393-15500
Rev:	As Built
Rev Date:	27 Apr 21





SECTION 1 - POWER DISTRIBUTION

VPX - J10

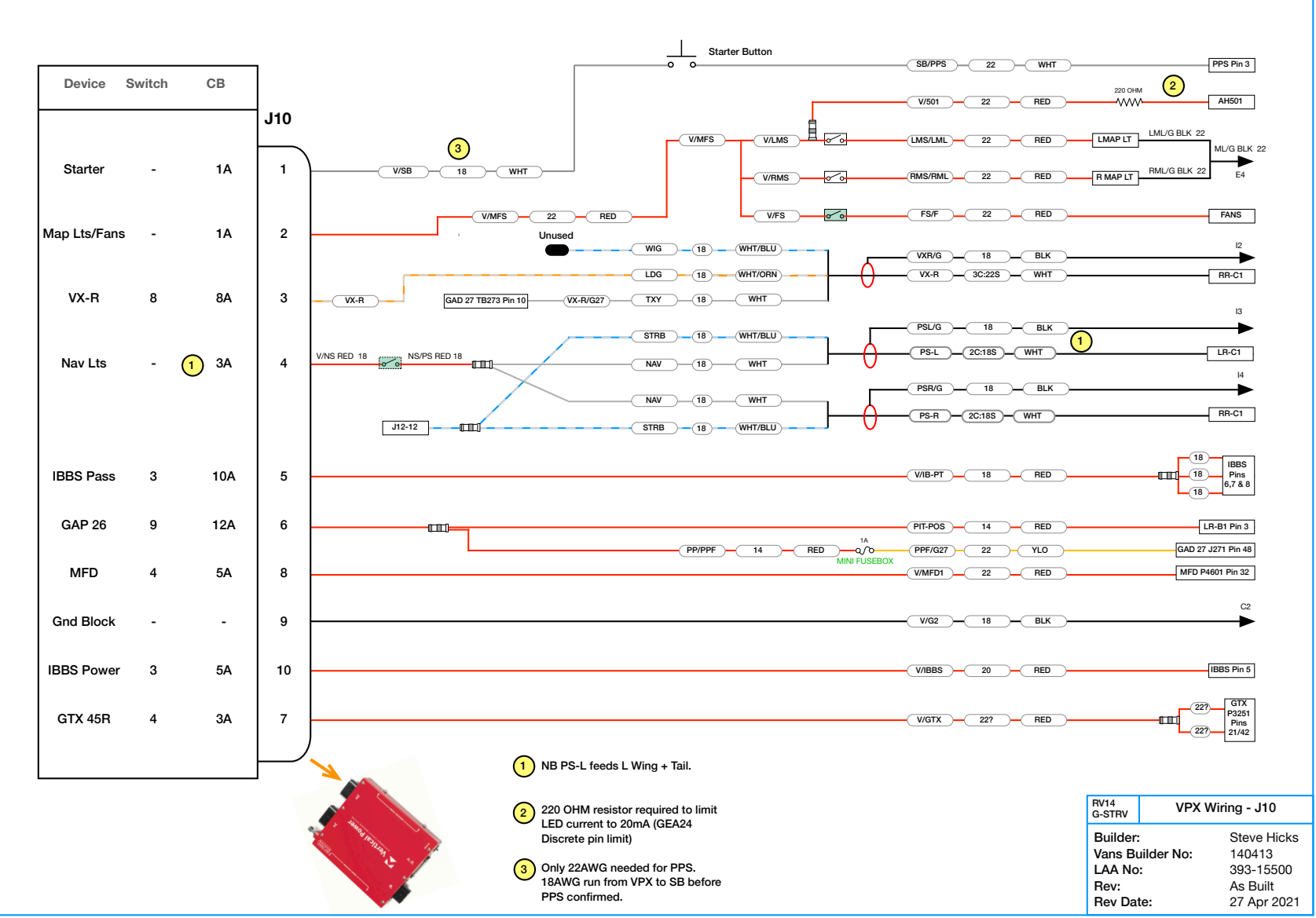





SECTION 1 - POWER DISTRIBUTION

Bus C

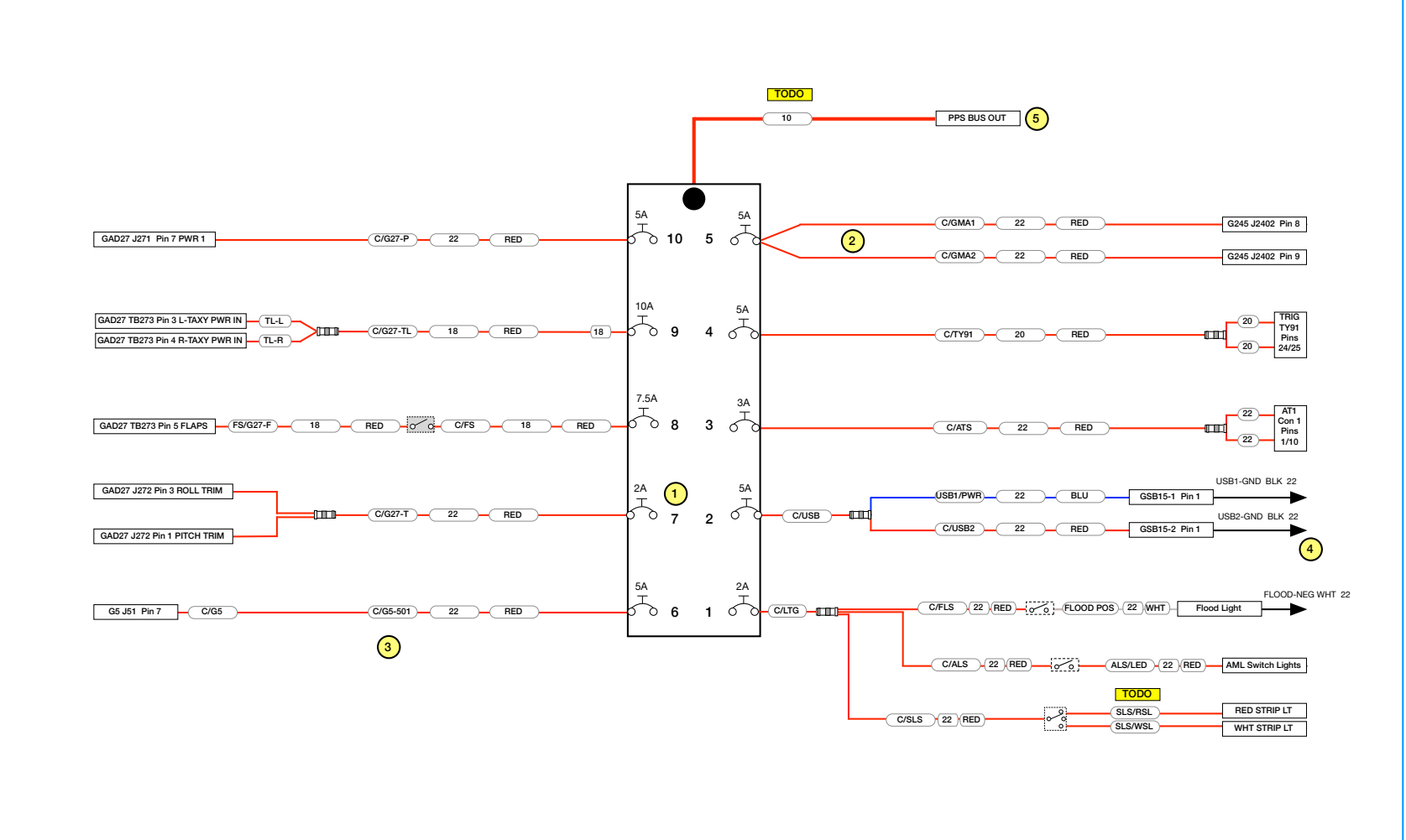

- 1 GAD27 Pinouts say 5A?
- 2 GMA 245 Installation says use 2 wires for power back to supply - NOT spliced at unit?
- 3 Wire function changed to just G5 after wire was labeled
- 4 USB2 Ground shared with Right Map Light ground
- 5 Connected at VPX Power Input

RV14 G-STRV	BUS C
Builder:	Steve Hicks
Vans Builder No:	140413
LAA No:	393-15500
Rev:	As Built
Rev Date:	27 Apr 2021



**VANS RV14 G-STRV**  
Electrical Reference Manual

# SECTION 1 - POWER DISTRIBUTION

## IBBS

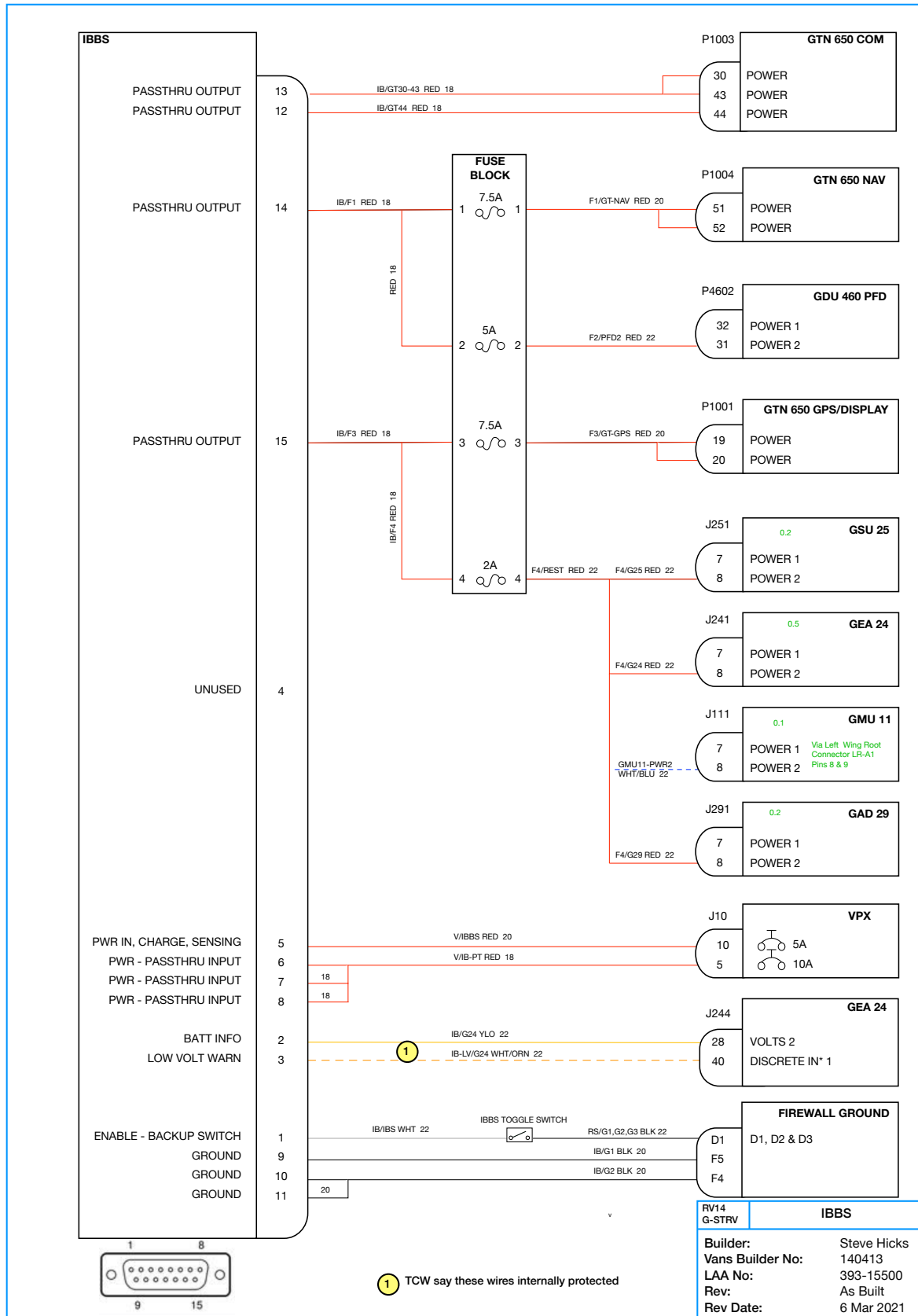



**VANS RV14 G-STRV**  
Electrical Reference Manual

# SECTION 1 - POWER DISTRIBUTION

## LR4D Voltage Regulator

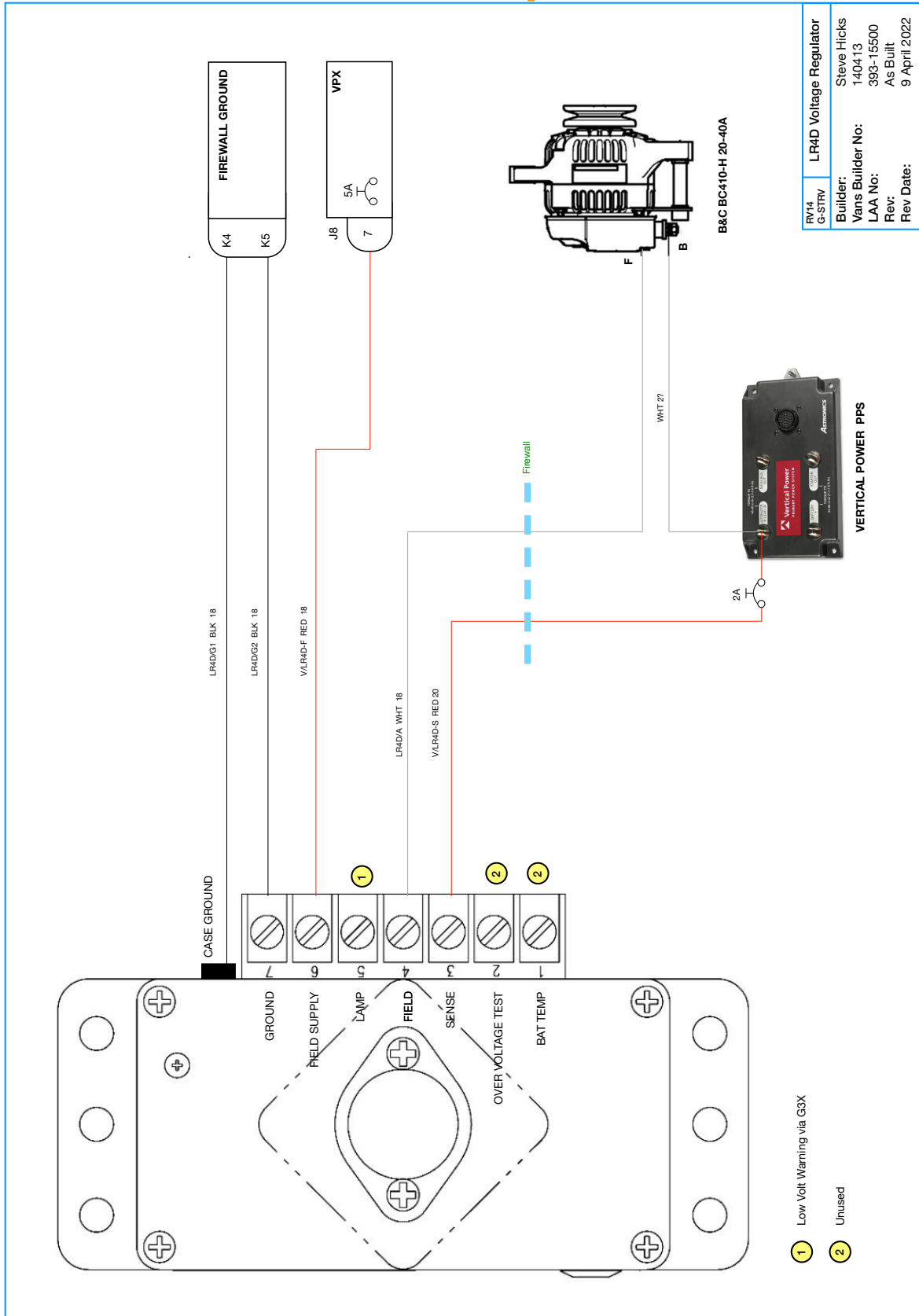

RV14 G-STRV	<b>LR4D Voltage Regulator</b>
Builder:	Steve Hicks
Vans Builder No:	140413
LAA No:	393-15500
Rev:	As Built
Rev Date:	9 April 2022



VANS RV14 G-STRV

# SECTION 1 - POWER DISTRIBUTION

## Rocker Switches

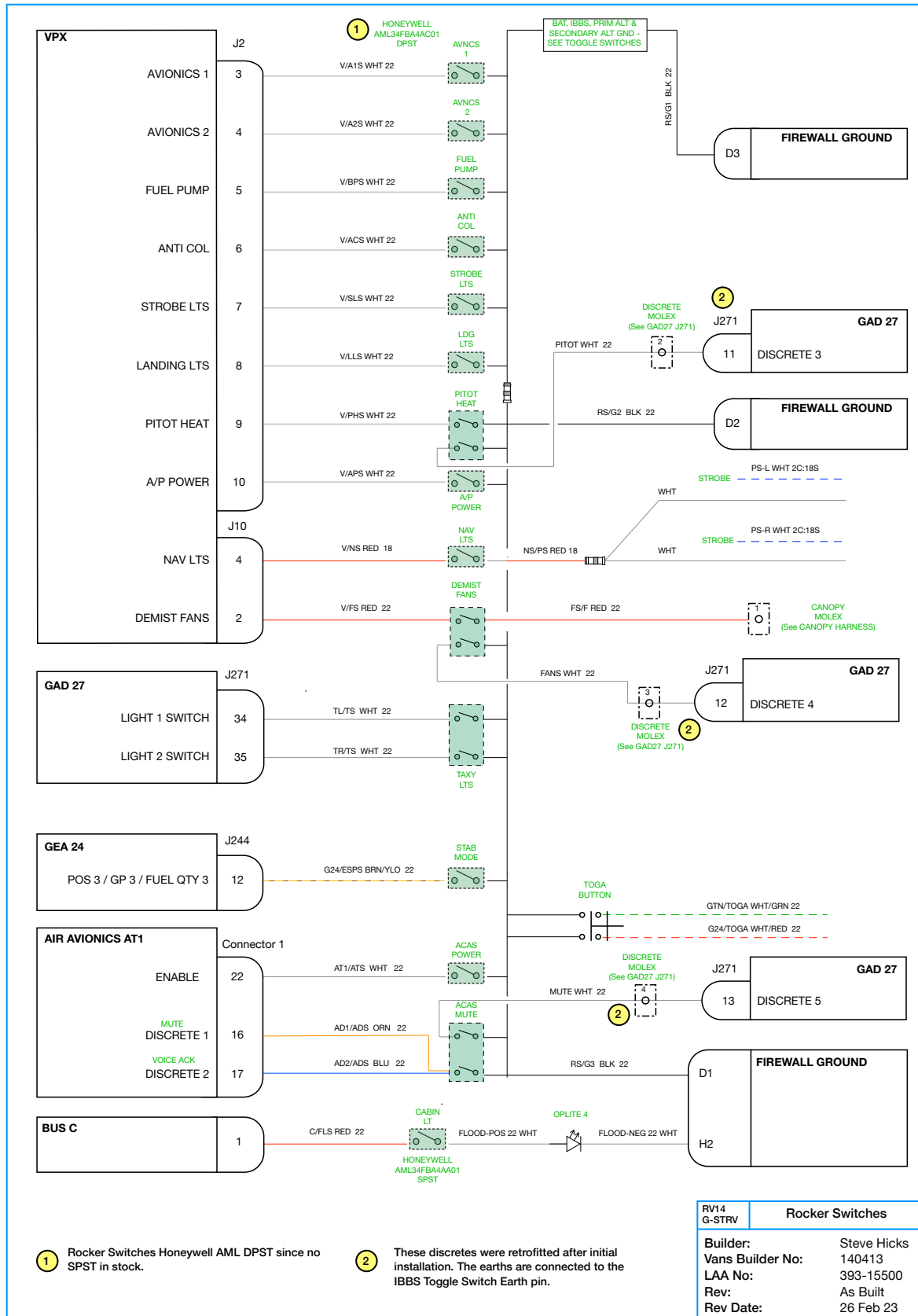

1 Rocker Switches Honeywell AML DPST since no SPST in stock.

2 These discretes were retrofitted after initial installation. The earths are connected to the IBBS Toggle Switch Earth pin.

RV14 G-STRV	Rocker Switches
Builder:	Steve Hicks
Vans Builder No:	140413
LAA No:	393-15500
Rev:	As Built
Rev Date:	26 Feb 23



**VANS RV14 G-STRV**  
Electrical Reference Manual

# SECTION 1 - POWER DISTRIBUTION

## Toggle Switches

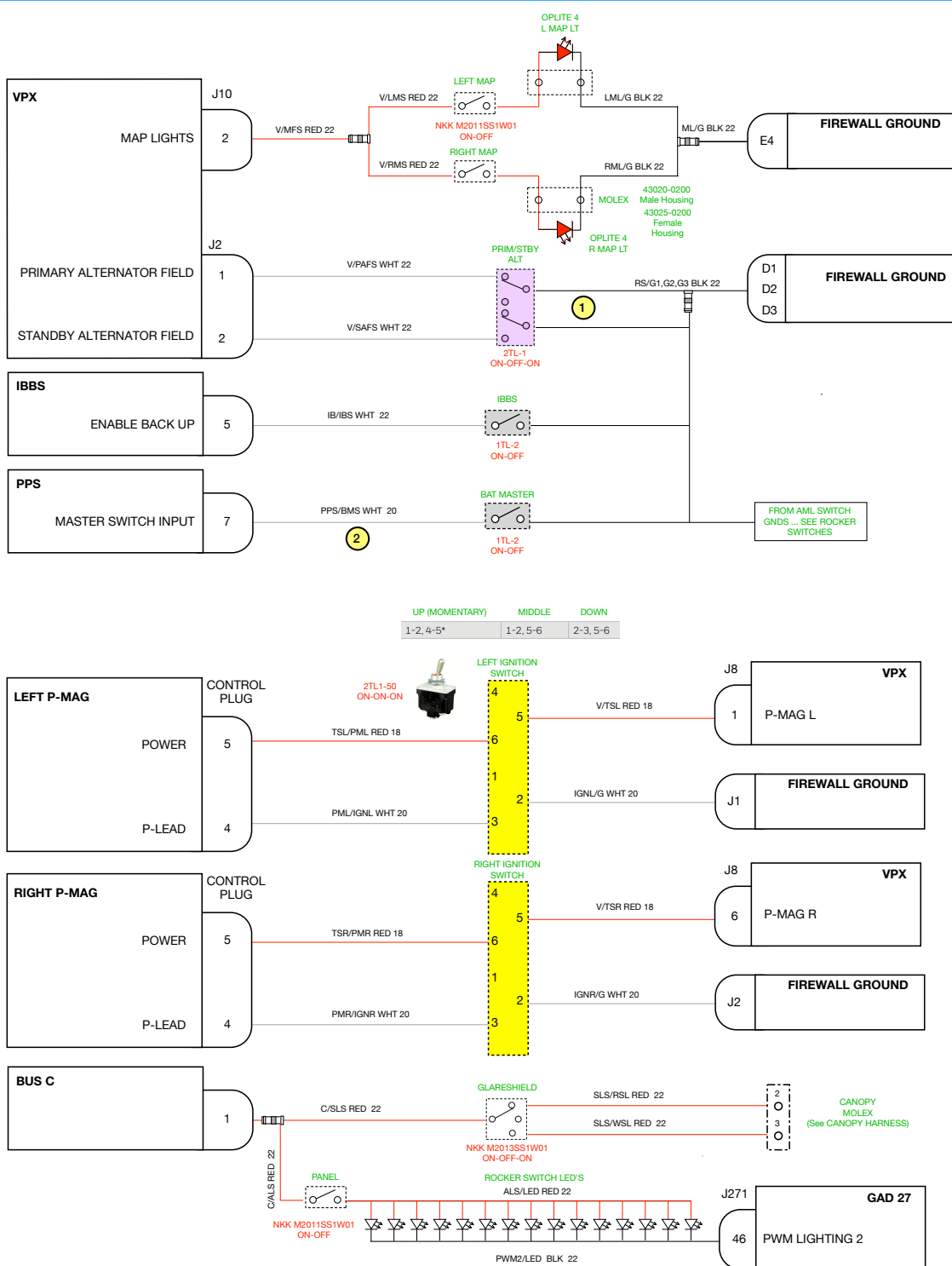

UP (MOMENTARY)	MIDDLE	DOWN
1-2, 4-5*	1-2, 5-6	2-3, 5-6

- ① Separate ground path for each alternator for redundancy
- ② 20AWG for firewall forward durability

RV14 G-STRV	Toggle Switches
Builder:	Steve Hicks
Vans Builder No:	140413
LAA No:	393-15500
Rev:	As Built
Rev Date:	29 Apr 21



**VANS RV14 G-STRV**  
Electrical Reference Manual

**SECTION 1 - POWER DISTRIBUTION**

**Lower Panel**

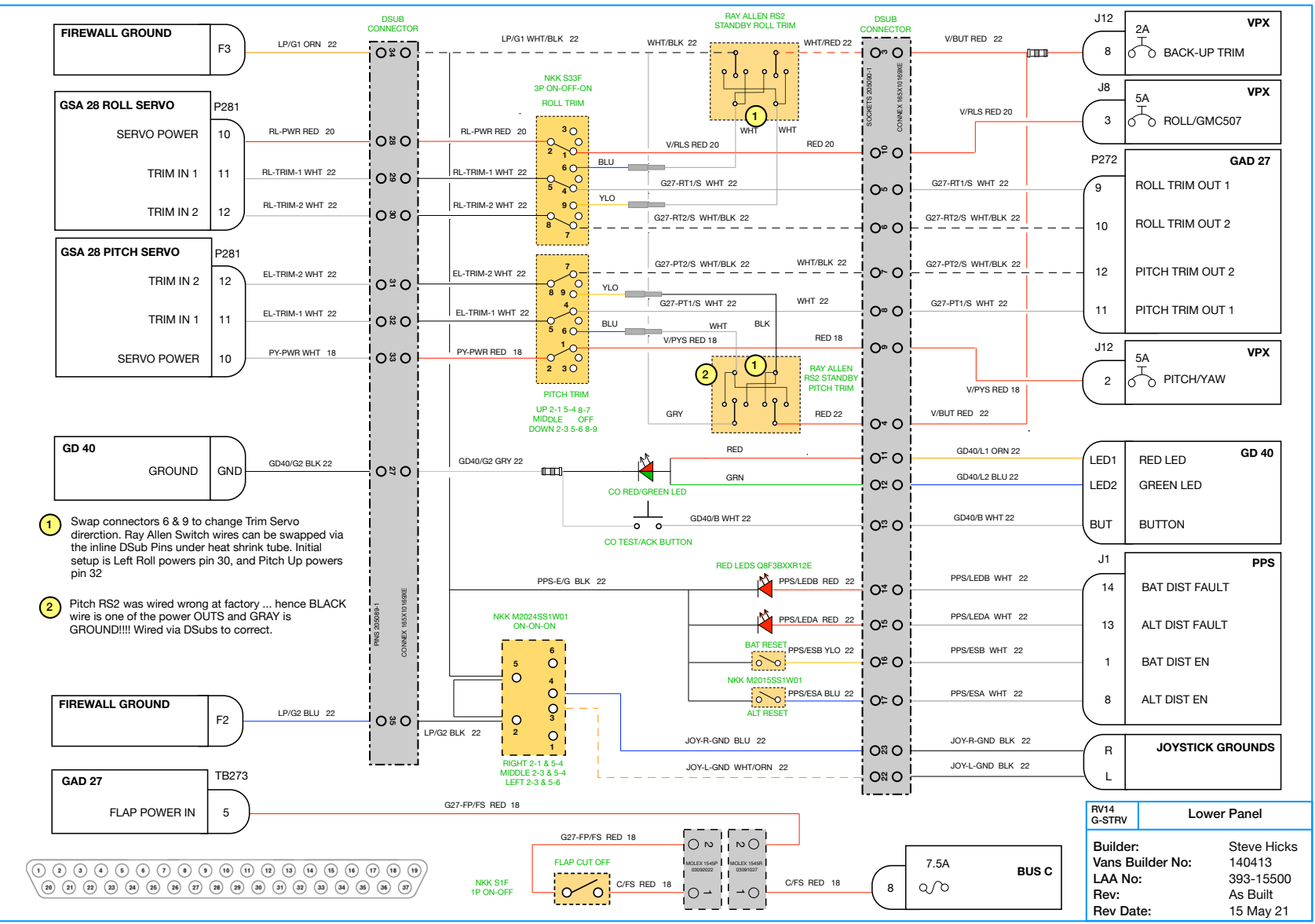



**VANS RV14 G-STRV**  
Electrical Reference Manual

**SECTION 1 - POWER DISTRIBUTION**

**Ground Block**

<b>A1</b> GMA/G2	<b>B1</b> GMA/G1	<b>C1</b> G29/G	<b>D1</b> RS/G3	<b>E1</b> G25/G	<b>F1</b> CH/G	<b>G1</b> G507/G	<b>H1</b> USB1/G	<b>I1</b> VXL/G	<b>J1</b> IGNL/G	<b>K1</b> PIT-NEG	<b>L1</b>
<b>A2</b> STUD	<b>B2</b> STUD	<b>C2</b> V/G2	<b>D2</b> RS/G2	<b>E2</b> G24/G	<b>F2</b> LP/G2	<b>G2</b> GTX/G	<b>H2</b> FLOOD/NEG	<b>I2</b> VXR/G	<b>J2</b> IGNR/G	<b>K2</b>	<b>L2</b>
<b>A3</b> GTN/G3	<b>B3</b> T90T91/G	<b>C3</b> V/G1	<b>D3</b> RS/G1	<b>E3</b> PBRK/G	<b>F3</b> LP/G1	<b>G3</b> G27/G	<b>H3</b> FS/G	<b>I3</b> PSL/G	<b>J3</b> FP/G	<b>K3</b>	<b>L3</b>
<b>A4</b> GTN/G1	<b>B4</b> AT1/G1	<b>C4</b> RL-GND	<b>D4</b> PFD/G1	<b>E4</b> ML/G USB2/G	<b>F4</b> IB/G2	<b>G4</b> G27-T/G	<b>H4</b> GMU11/G	<b>I4</b> PSR/G	<b>J4</b> PUMP-GND	<b>K4</b> LR4D/G1	<b>L4</b>
<b>A5</b> GTN/G4	<b>B5</b> AT1/G2	<b>C5</b> PY-GND	<b>D5</b> PFD/G2	<b>E5</b> GD40/G1	<b>F5</b> IB/G1	<b>G5</b> MFD/G	<b>H5</b> G5/G	<b>I5</b> SB/G	<b>J5</b> G27-SS/G	<b>K5</b> LR4D/G2	<b>L5</b>

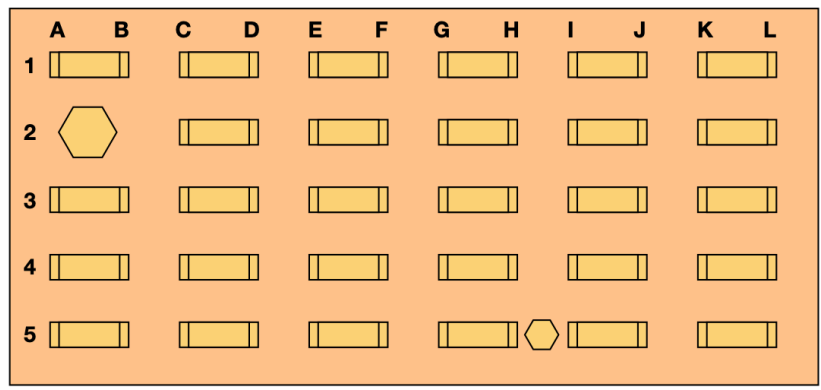

RV14 G-STRV	<b>Ground Block</b>	
<b>Builder:</b>	Steve Hicks	
<b>Vans Builder No:</b>	140413	
<b>LAA No:</b>	393-15500	
<b>Rev:</b>	As Built	
<b>Rev Date:</b>	15 May 21	



**VANS RV14 G-STRV**  
Electrical Reference Manual

## SECTION 2 - AIRFRAME HARNESSSES

### Index



<b>LEFT FUSELAGE</b>	<b>2 - 2</b>
<b>RIGHT FUSELAGE</b>	<b>2 - 3</b>
<b>LEFT TAILCONE</b>	<b>2 - 4</b>
<b>RIGHT TAILCONE - SERVOS</b>	<b>2 - 5</b>
<b>LEFT WING</b>	<b>2 - 6</b>
<b>RIGHT WING</b>	<b>2 - 7</b>
<b>RIGHT WING - SERVOS</b>	<b>2 - 8</b>
<b>CANOPY</b>	<b>2 - 9</b>
<b>AUDIO AND JOYSTICKS</b>	<b>2 - 10</b>
<b>IGNITION HARNESS</b>	<b>2 - 11</b>



# SECTION 2 - AIRFRAME HARNESSSES

## Left Fuselage

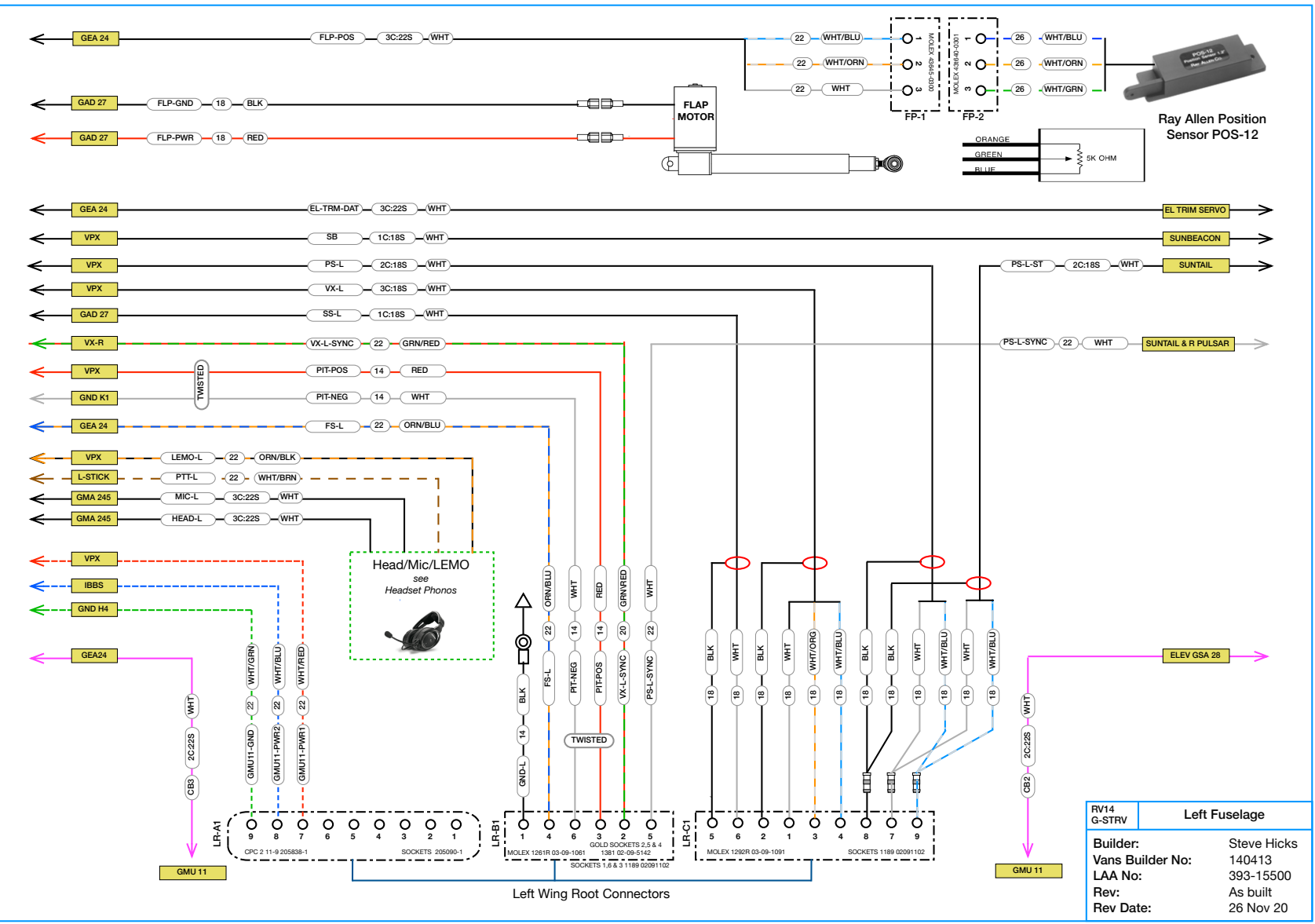



**VANS RV14 G-STRV**  
Electrical Reference Manual

**SECTION 2 - AIRFRAME HARNESSSES**

**Right Fuselage**

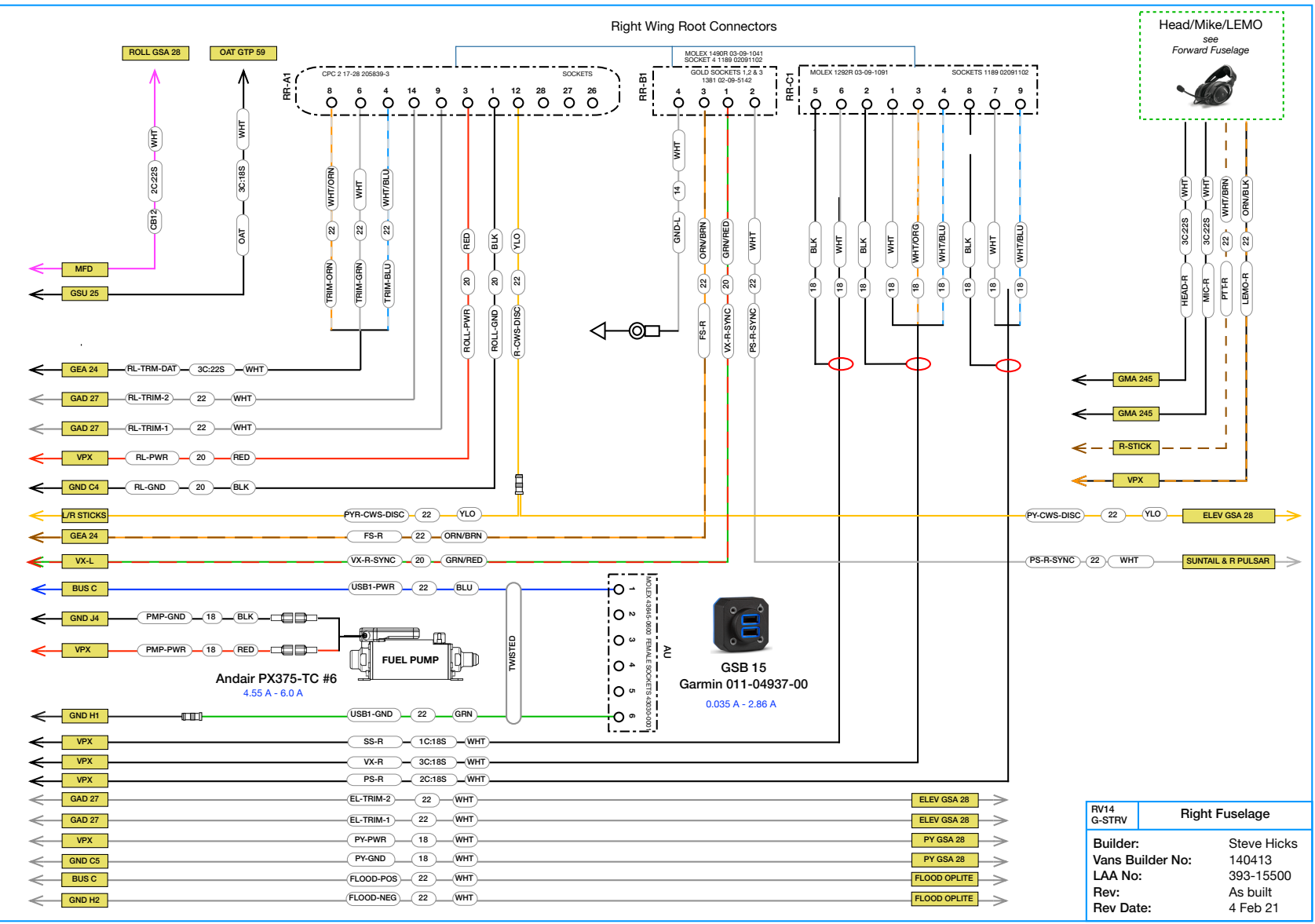



**VANS RV14 G-STRV**  
Electrical Reference Manual

# SECTION 2 - AIRFRAME HARNESSSES

## Left Tailcone

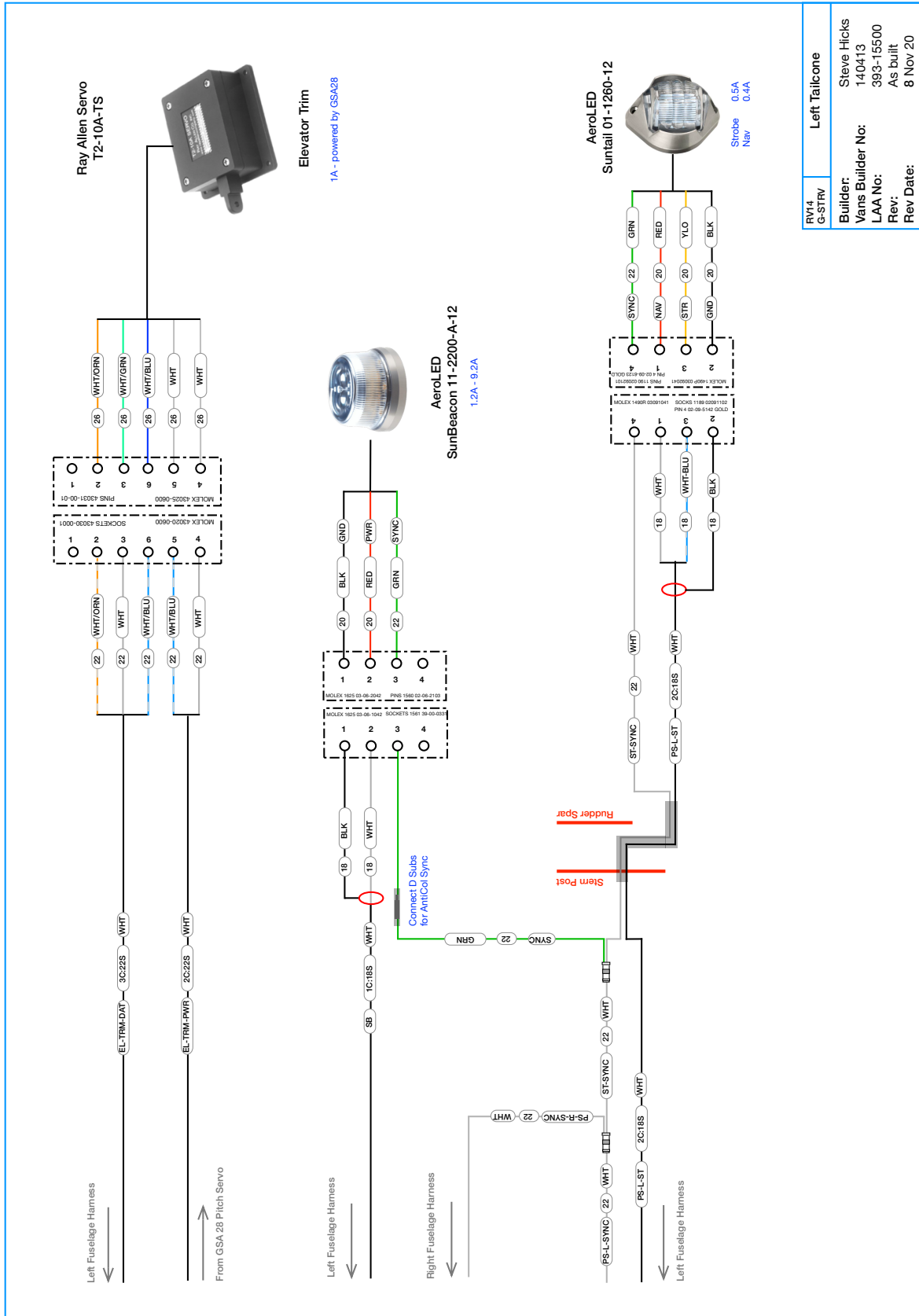

RV14 G-STRV	<b>Left Tailcone</b>
Builder:	Steve Hicks
Vans Builder No:	140413
LAA No:	393-15500
Rev:	As built
Rev Date:	8 Nov 20



**VANS RV14 G-STRV**  
Electrical Reference Manual

# SECTION 2 - AIRFRAME HARNESSSES

## Right Tailcone - Servos

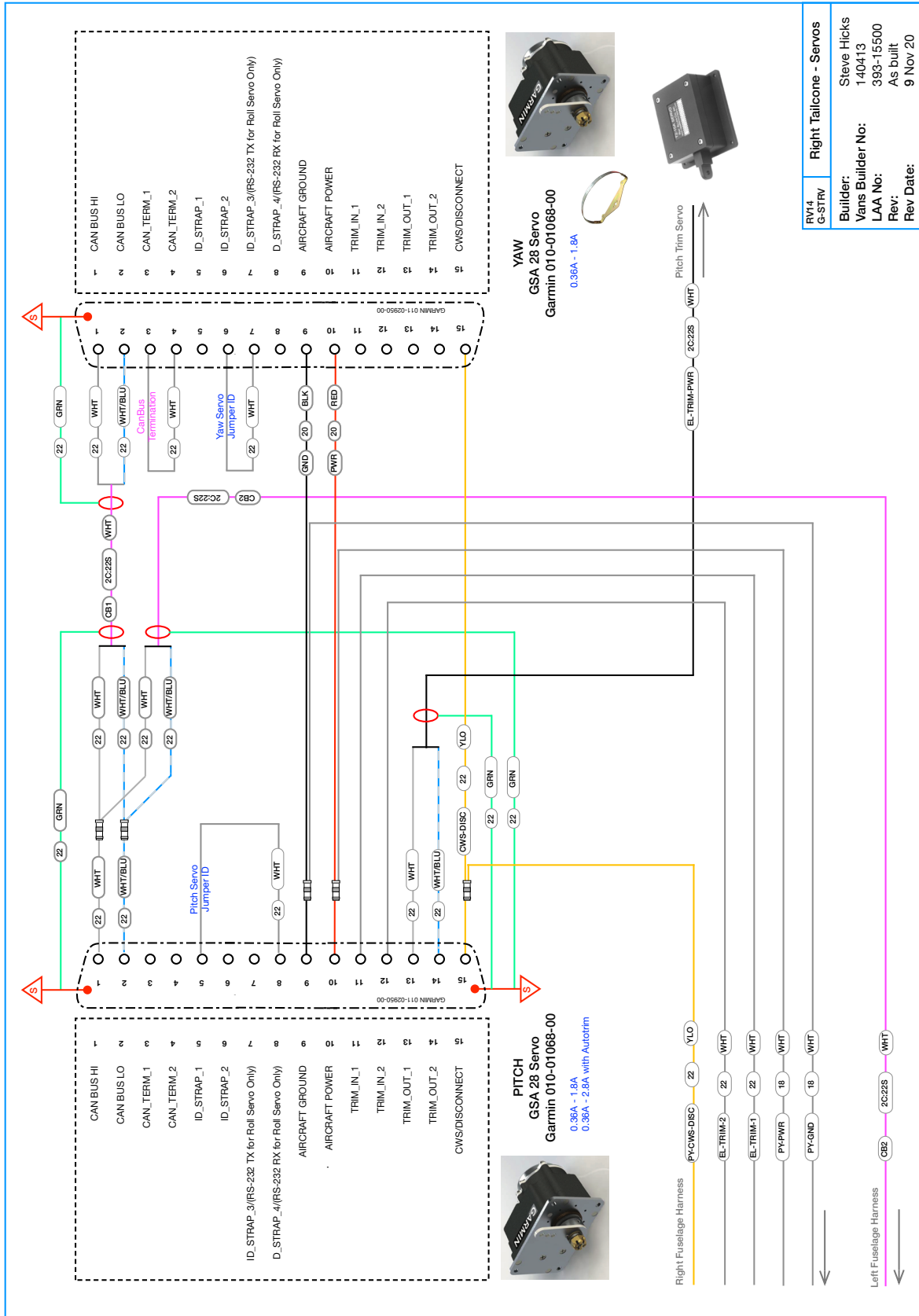

RV14 G-STRV	Right Tailcone - Servos
Builder:	Steve Hicks
Vans Builder No:	140413
LAA No:	393-15500
Rev:	As built
Rev Date:	9 Nov 20



**VANS RV14 G-STRV**  
Electrical Reference Manual

**SECTION 2 - AIRFRAME HARNESSSES**

**Left Wing**

RV14 G-STRV	Left Wing
Builder:	Steve Hicks
Vans Builder No:	140413
LAA No:	393-15500
Rev:	As built
Rev Date:	6 Nov 20

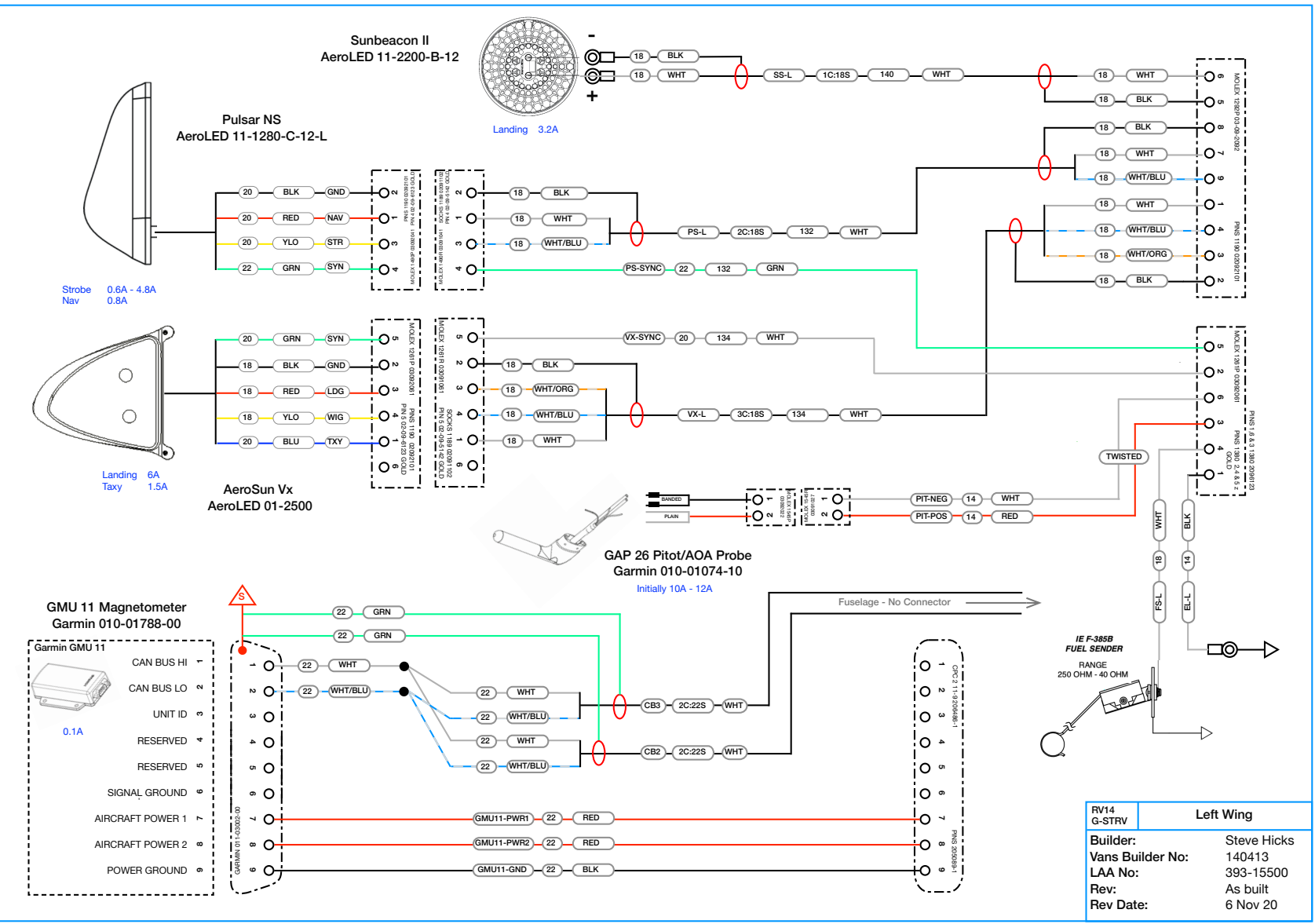



**VANS RV14 G-STRV**  
Electrical Reference Manual

**SECTION 2 - AIRFRAME HARNESSSES**

**Right Wing**

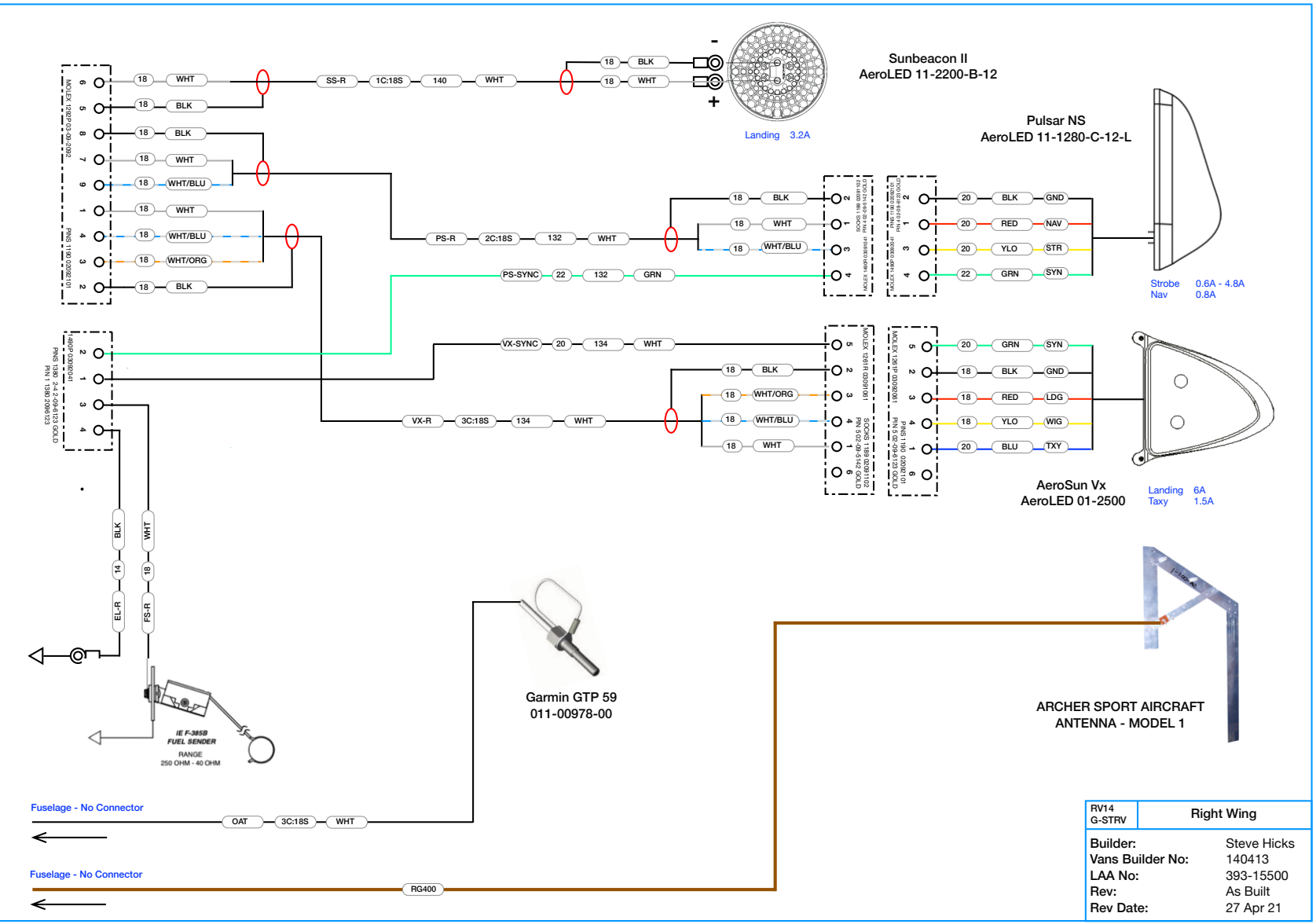

RV14 G-STRV	Right Wing
Builder:	Steve Hicks
Vans Builder No:	140413
LAA No:	393-15500
Rev:	As Built
Rev Date:	27 Apr 21



# SECTION 2 - AIRFRAME HARNESSSES

## Right Wing - Servos

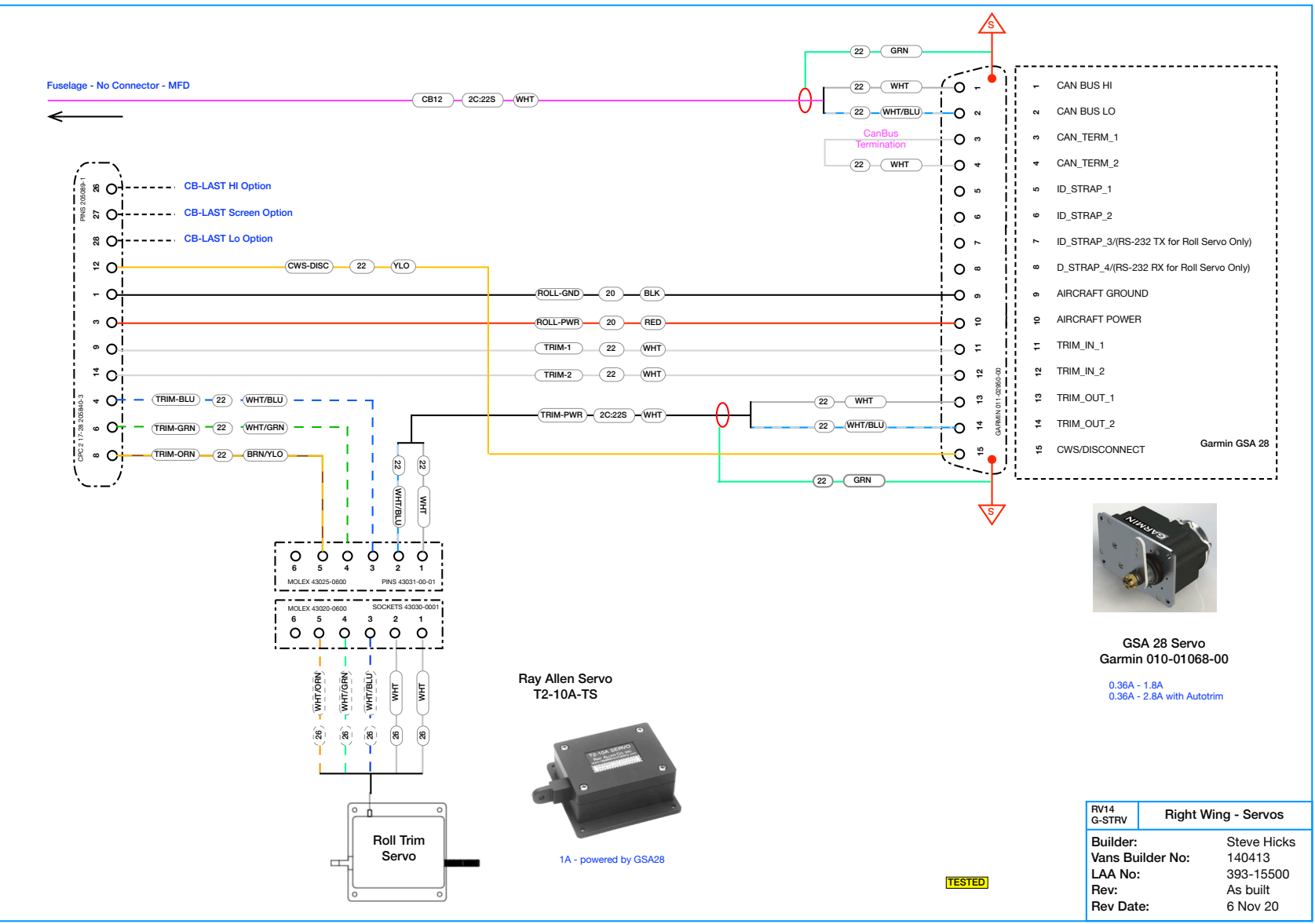

RV14 G-STRV	Right Wing - Servos
Builder:	Steve Hicks
Vans Builder No:	140413
LAA No:	393-15500
Rev:	As built
Rev Date:	6 Nov 20



**VANS RV14 G-STRV**  
Electrical Reference Manual

# SECTION 2 - AIRFRAME HARNESSSES

## Canopy

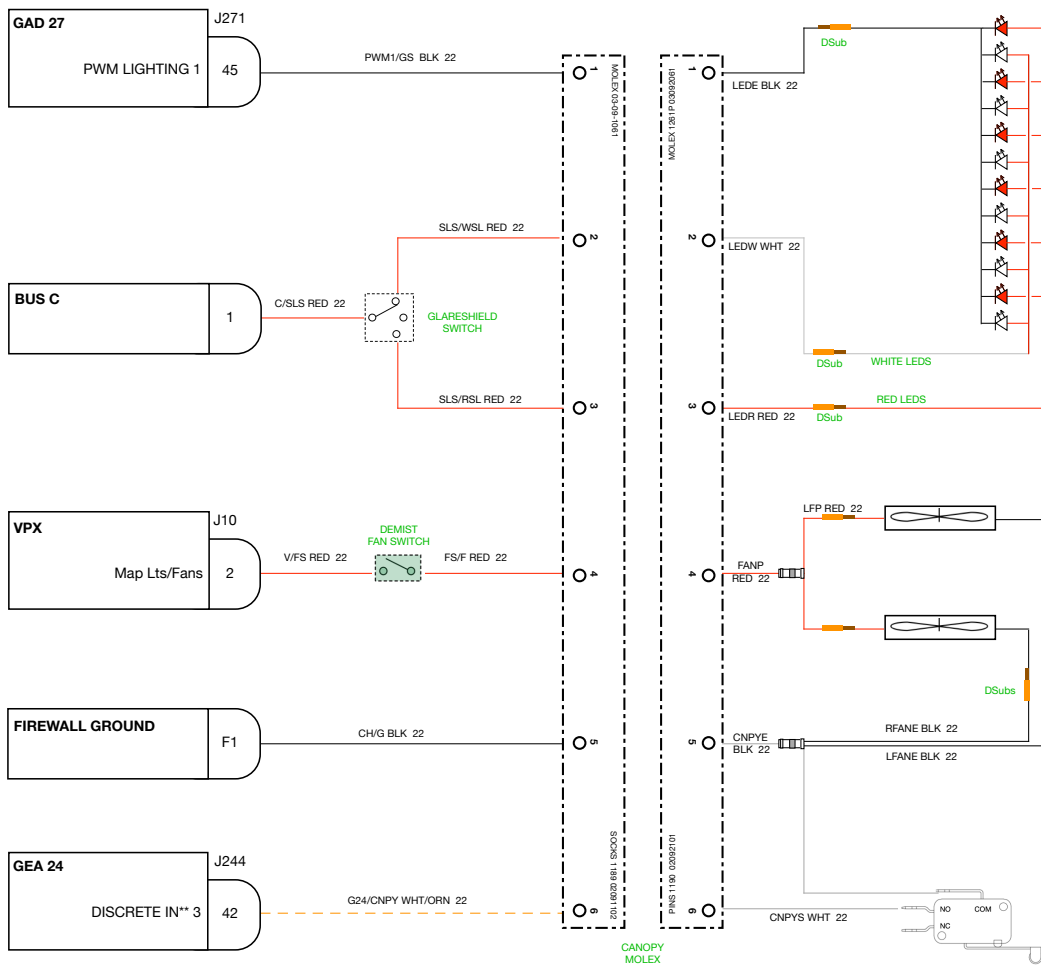

RV14 G-STRV	Canopy Harness
Builder:	Steve Hicks
Vans Builder No:	140413
LAA No:	393-15500
Rev:	As Built
Rev Date:	20 May 22



# SECTION 2 - AIRFRAME HARNESSSES

## Audio and Joysticks

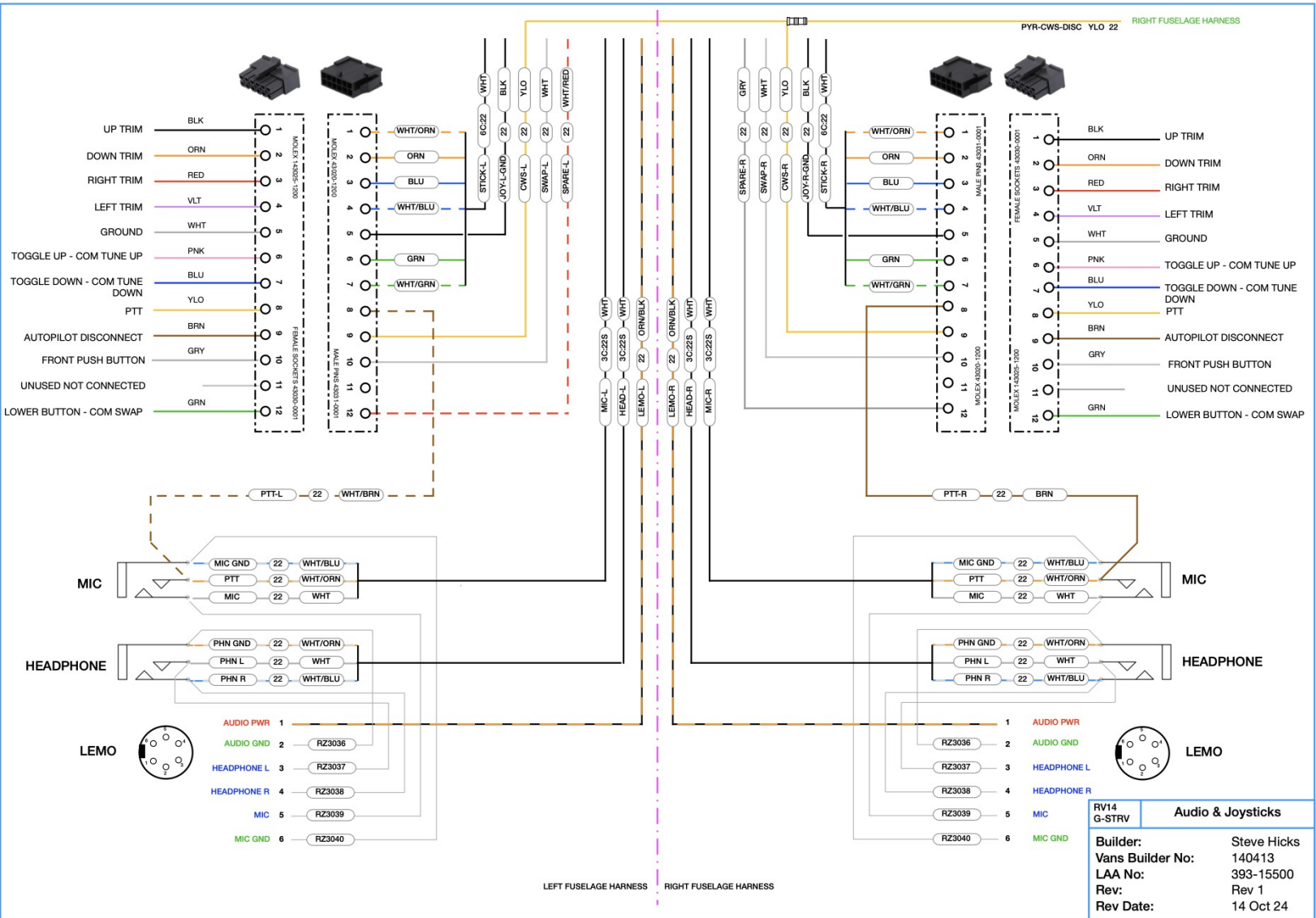

RV14 G-STRV		Audio & Joysticks	
Builder:	Steve Hicks		
Vans Builder No:	140413		
LAA No:	393-15500		
Rev:	Rev 1		
Rev Date:	14 Oct 24		



**VANS RV14 G-STRV**  
Electrical Reference Manual

## SECTION 2 - AIRFRAME HARNESSSES

### Ignition Harness

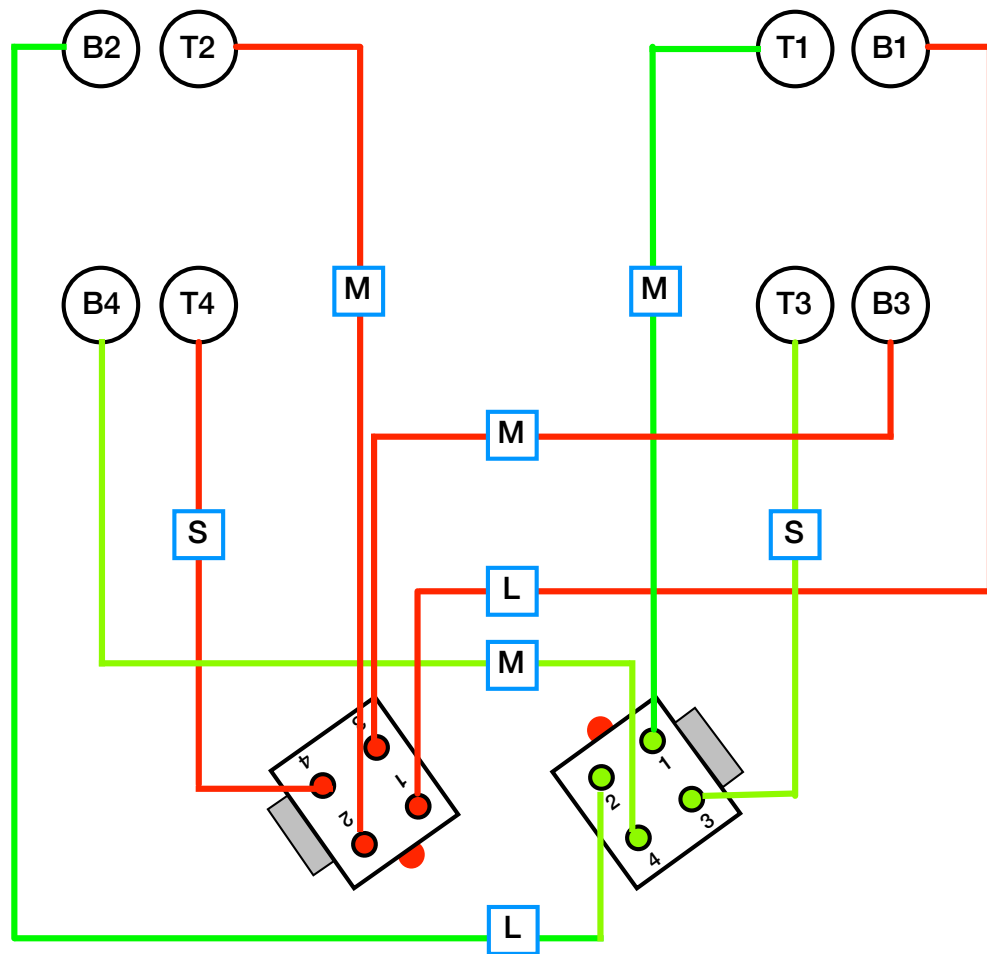

- S** Short Lead
- M** Medium Lead
- L** Long Lead

RV14 G-STRV	Ignition Harness
Builder:	Steve Hicks
Vans Builder No:	140413
LAA No:	393-15500
Rev:	Rev 1
Rev Date:	25 Apr 2022



**VANS RV14 G-STRV**  
Electrical Reference Manual

## SECTION 3 - AVIONICS

### Index

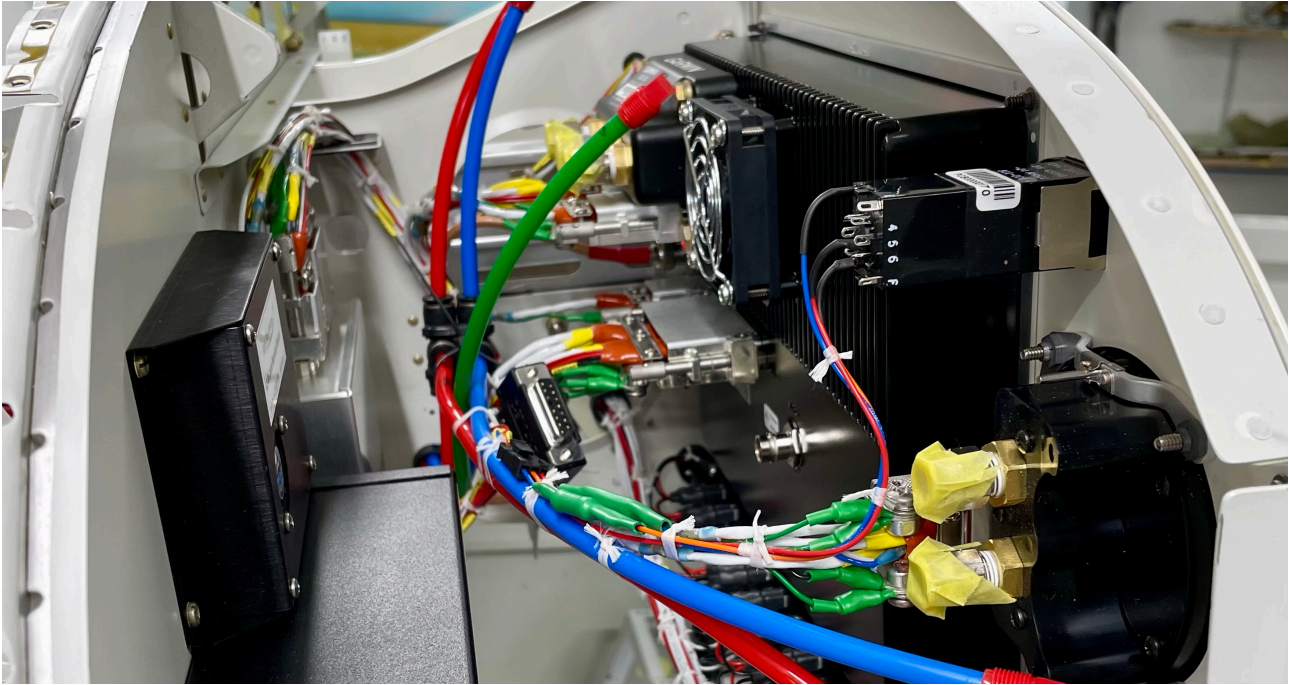

<b>G3X SYSTEM DATA CONNECTION SCHEMATIC</b>	<b>3 - 3</b>
<b>AIR AVIONICS AT-1 and ATD-80</b>	<b>3 - 4</b>
<b>CANBUS</b>	<b>3 - 5</b>
<b>G5</b>	<b>3 - 6</b>
<b>GAD 27 J271</b>	<b>3 - 7</b>
<b>GAD 27 J271 LIGHTING</b>	<b>3 - 8</b>
<b>GAD 27 J272 and TB273</b>	<b>3 - 9</b>
<b>GAD 29</b>	<b>3 - 10</b>
<b>GD-40</b>	<b>3 - 11</b>
<b>GDU 460 MFD</b>	<b>3 - 12</b>
<b>GDU 460 PFD P4601</b>	<b>3 - 13</b>
<b>GDU 460 PFD P4602</b>	<b>3 - 14</b>



**VANS RV14 G-STRV**  
Electrical Reference Manual

## SECTION 3 - AVIONICS

### Index



<b>GEA 24 J241 and J242</b>	<b>3 - 15</b>
<b>GEA 24 J243</b>	<b>3 - 16</b>
<b>GEA 24 J244</b>	<b>3 - 17</b>
<b>GMA 245 J2401</b>	<b>3 - 18</b>
<b>GMA 245 J2402</b>	<b>3 - 19</b>
<b>GMC 507</b>	<b>3 - 20</b>
<b>GMU 11</b>	<b>3 - 21</b>
<b>GSU 25</b>	<b>3 - 22</b>
<b>GTN 650Xi P1001</b>	<b>3 - 23</b>
<b>GTN 650Xi P1002 and P1003</b>	<b>3 - 24</b>
<b>GTN 650Xi P1004</b>	<b>3 - 25</b>
<b>GTX 45R</b>	<b>3 - 26</b>
<b>TRIG TY91 and TC90</b>	<b>3 - 27</b>
<b>PMAGS</b>	<b>3 - 28</b>
<b>STANDBY TRIM OVERVIEW</b>	<b>3 - 29</b>



**VANS RV14 G-STRV**  
Electrical Reference Manual

## SECTION 3 - AVIONICS

### G3X System Data Connection Schematic

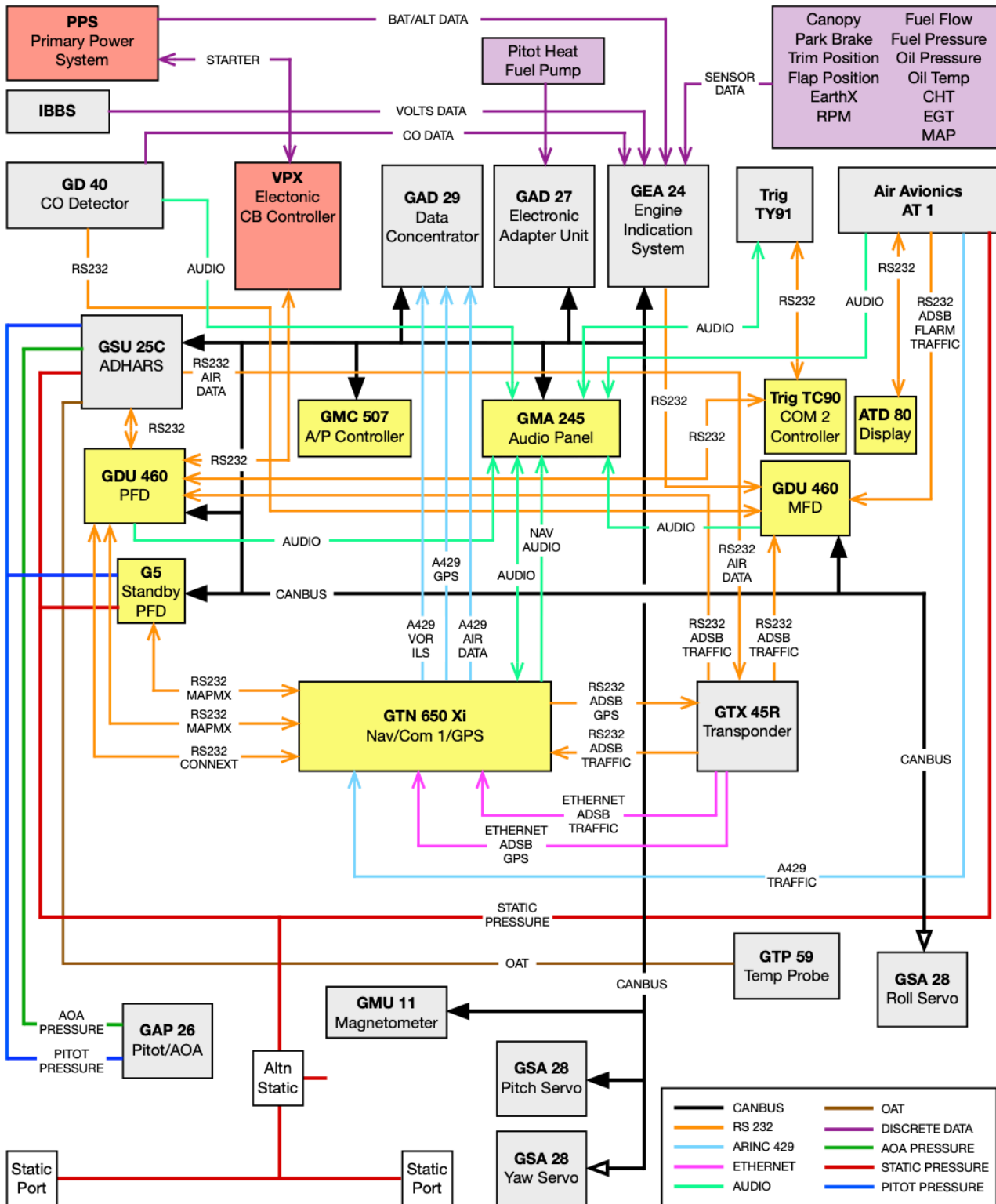



**VANS RV14 G-STRV**  
Electrical Reference Manual

# SECTION 3 - AVIONICS

## Air Avionics AT-1 and ATD-80

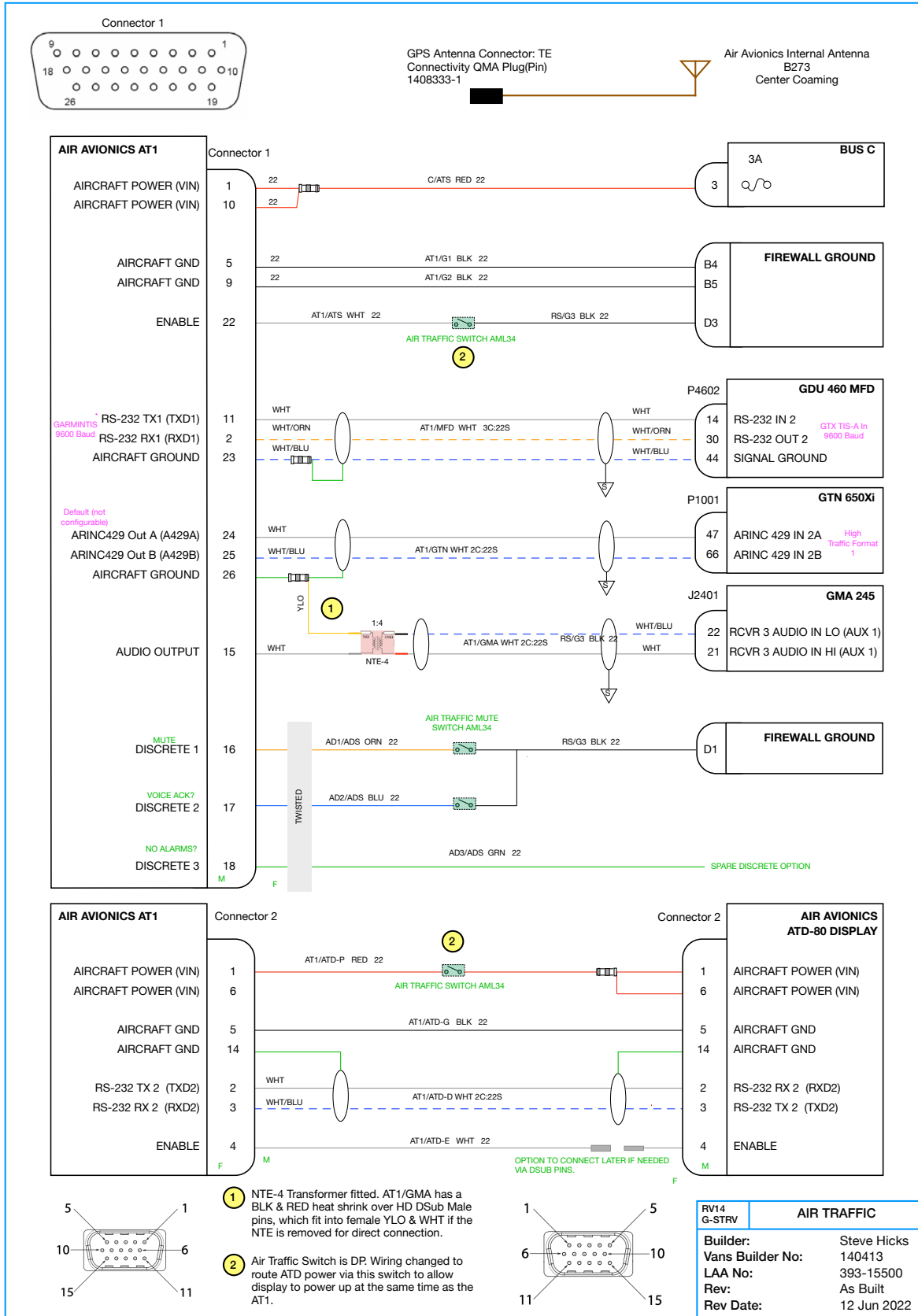



**VANS RV14 G-STRV**  
Electrical Reference Manual

# SECTION 3 - AVIONICS

## CanBus

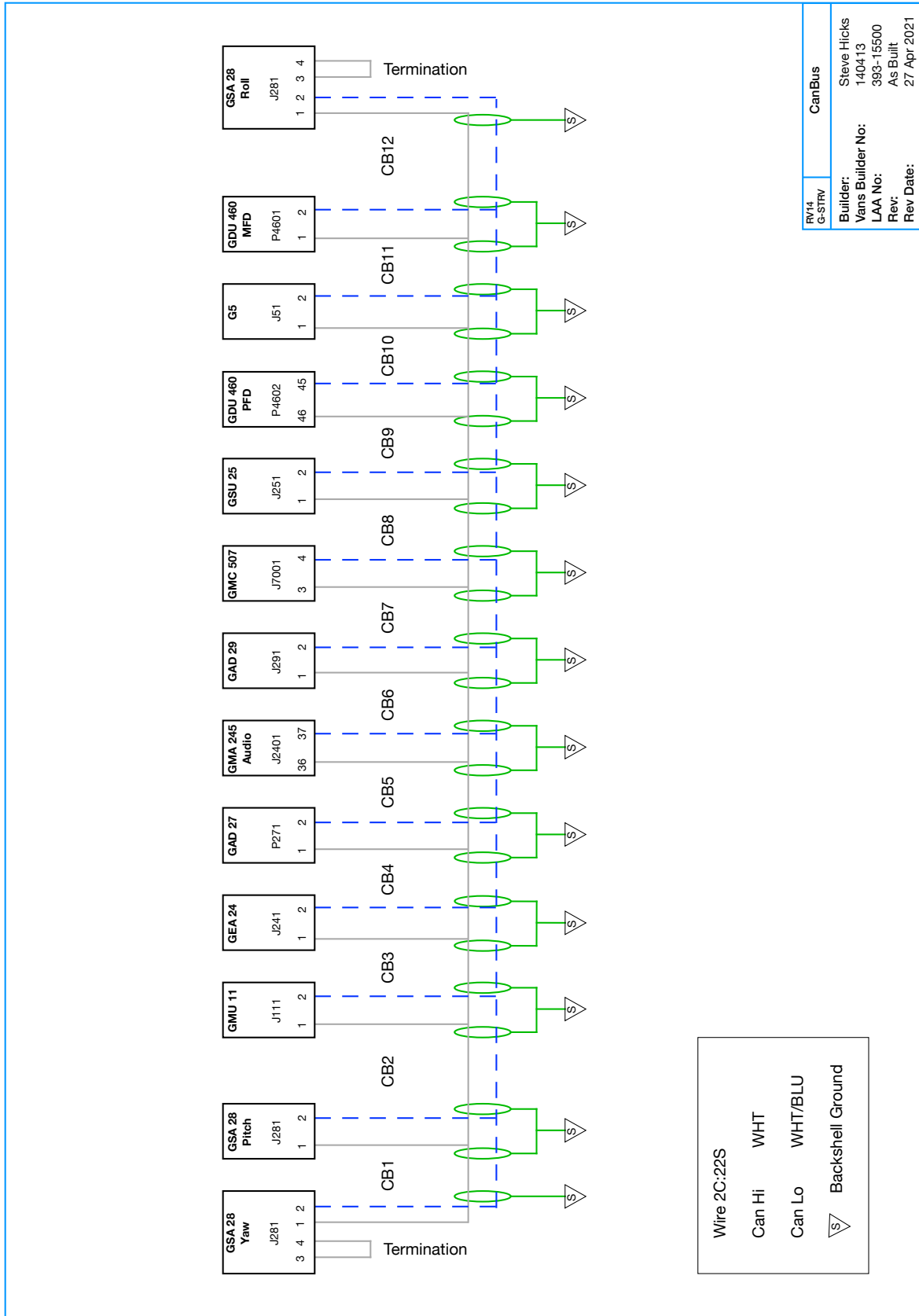



**VANS RV14 G-STRV**  
Electrical Reference Manual

# SECTION 3 - AVIONICS

## G5

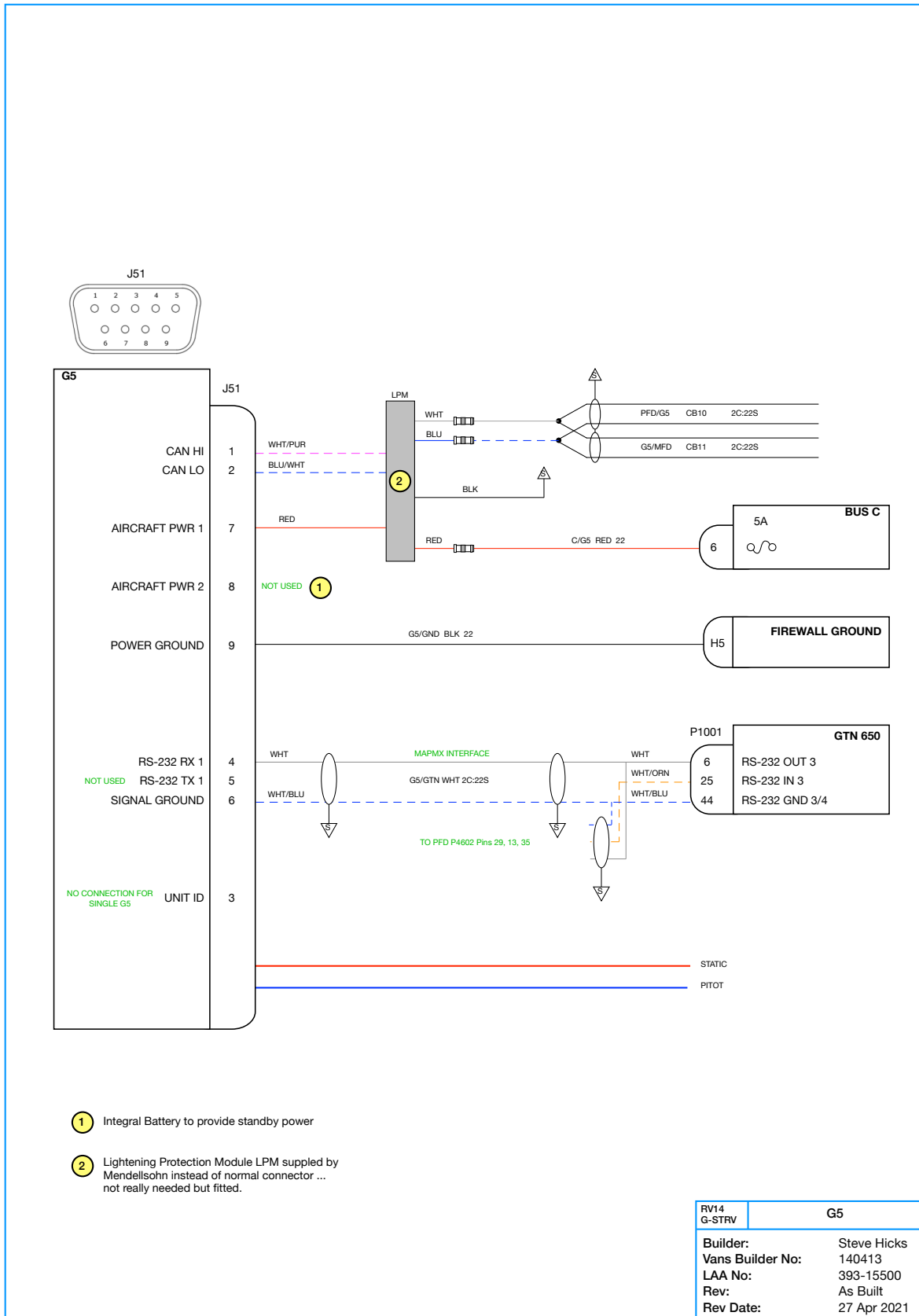

- ① Integral Battery to provide standby power
- ② Lightning Protection Module LPM supplied by Mendelsohn instead of normal connector ... not really needed but fitted.

RV14 G-STRV	G5
Builder:	Steve Hicks
Vans Builder No:	140413
LAA No:	393-15500
Rev:	As Built
Rev Date:	27 Apr 2021



VANS RV14 G-STRV

# SECTION 3 - AVIONICS

## GAD 27 J271

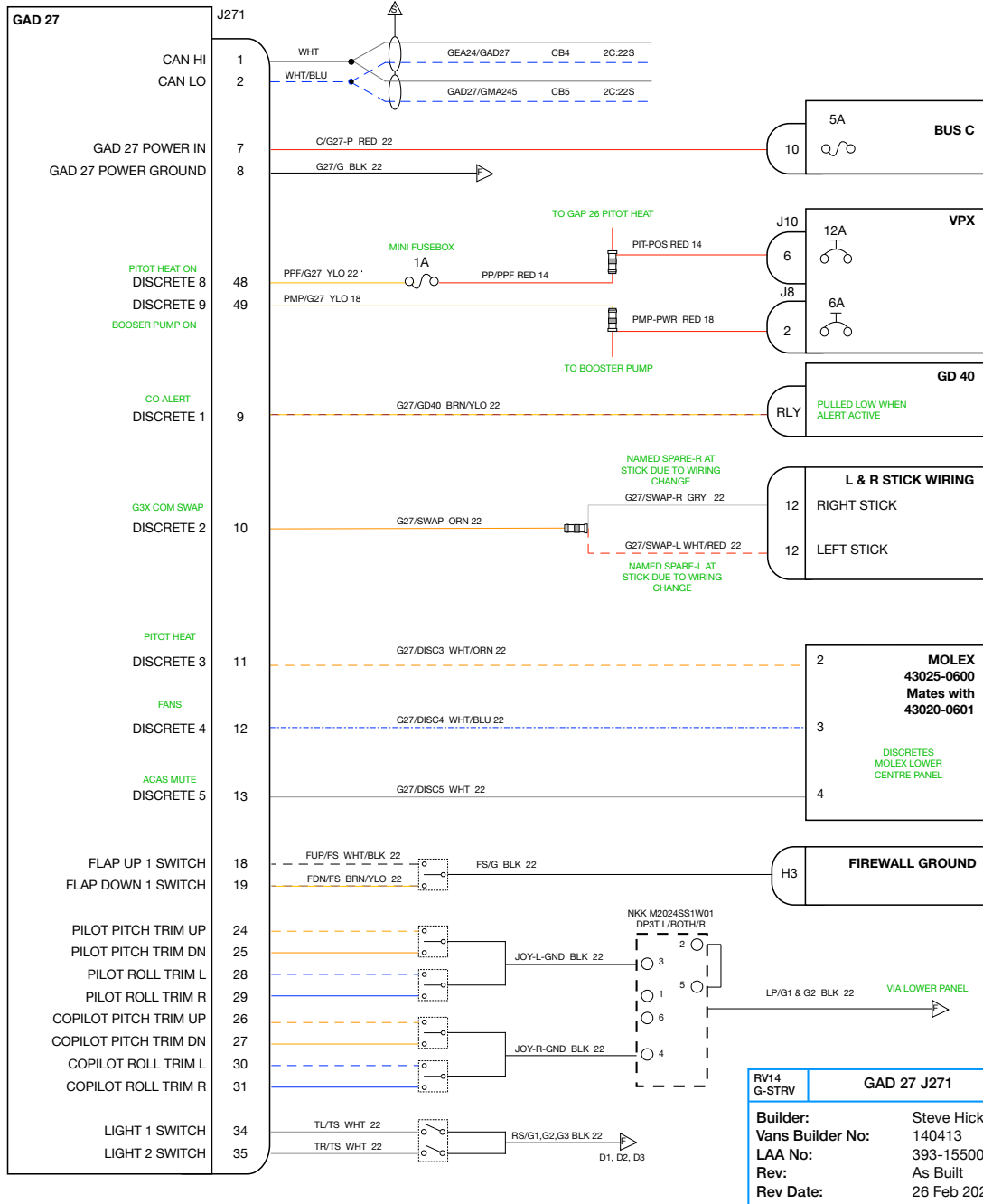
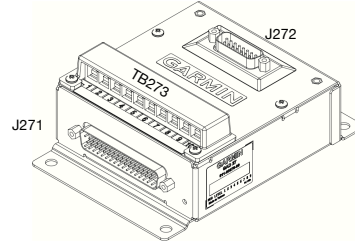
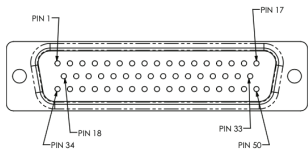



**VANS RV14 G-STRV**  
Electrical Reference Manual

# SECTION 3 - AVIONICS

## GAD 27 J271 Lighting

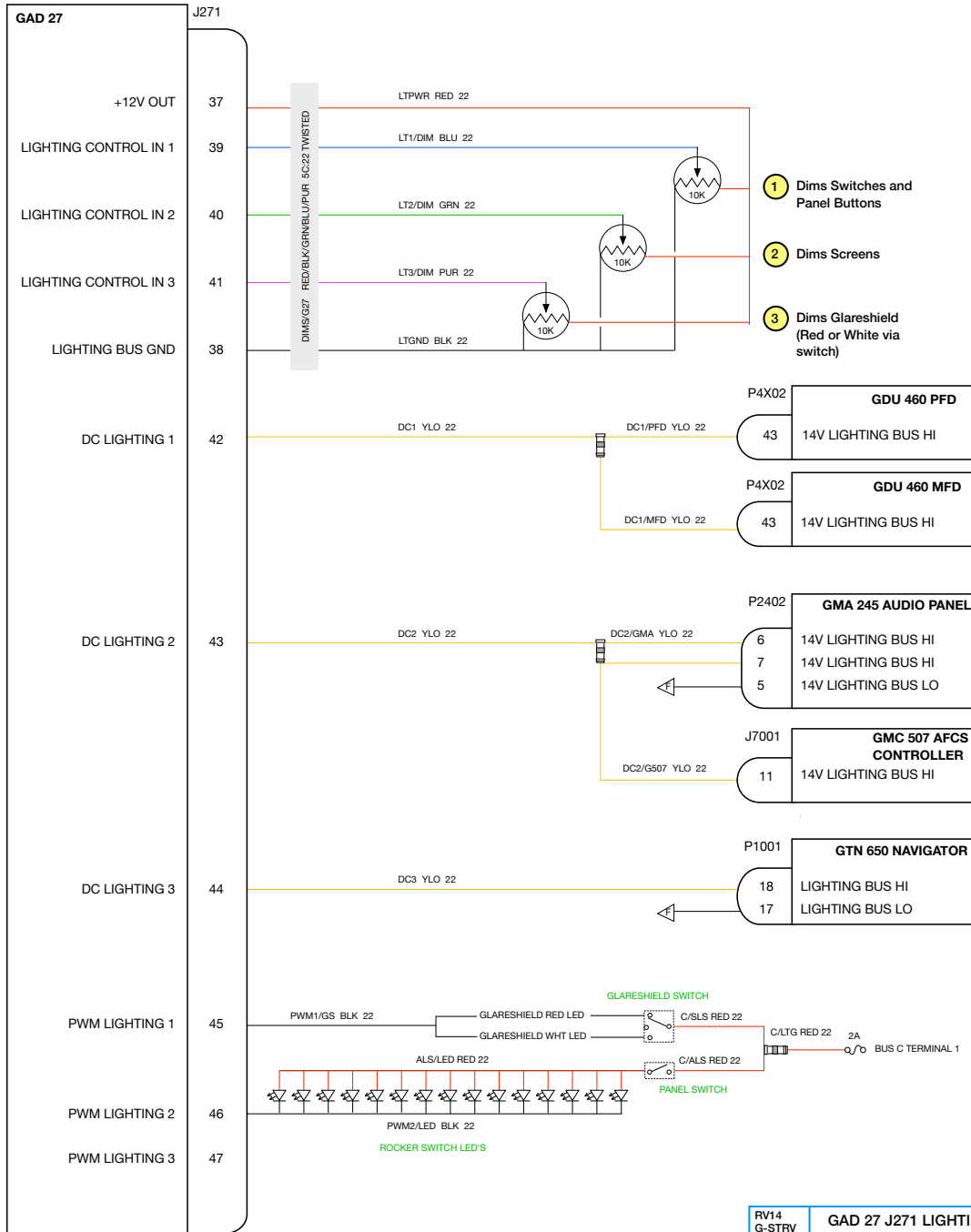
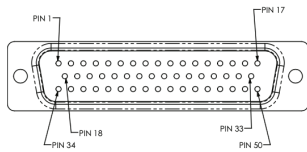

RV14 G-STRV	GAD 27 J271 LIGHTING
Builder:	Steve Hicks
Vans Builder No:	140413
LAA No:	393-15500
Rev:	As Built
Rev Date:	27 Apr 2021



**VANS RV14 G-STRV**  
Electrical Reference Manual

# SECTION 3 - AVIONICS

## GAD 27 J272 and TB273

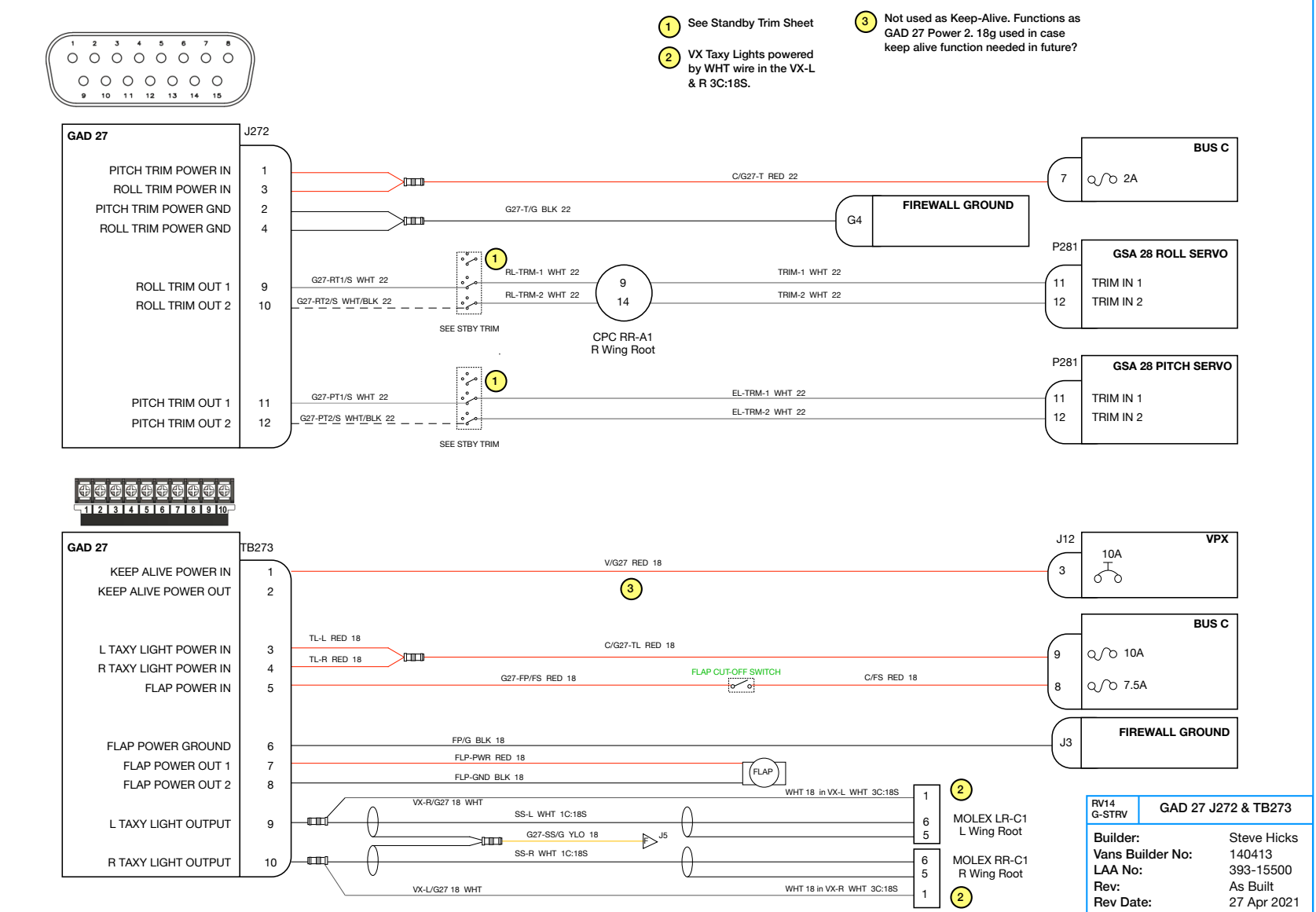

RV14 G-STRV	GAD 27 J272 & TB273
<b>Builder:</b>	Steve Hicks
<b>Vans Builder No:</b>	140413
<b>LAA No:</b>	393-15500
<b>Rev:</b>	As Built
<b>Rev Date:</b>	27 Apr 2021



**VANS RV14 G-STRV**  
Electrical Reference Manual

# SECTION 3 - AVIONICS

## GAD 29

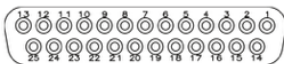
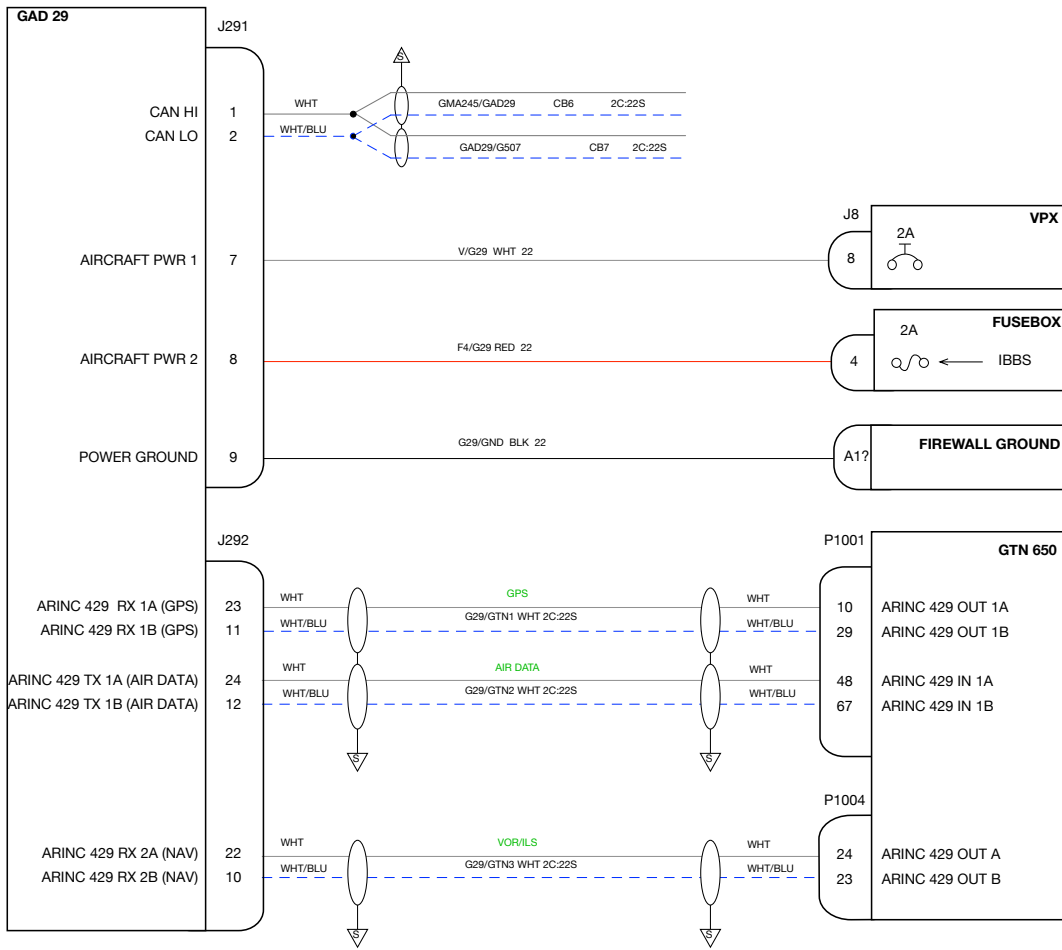
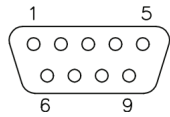

RV14 G-STRV	GAD 29
Builder:	Steve Hicks
Vans Builder No:	140413
LAA No:	393-15500
Rev:	As Built
Rev Date:	27 Apr 2021



**VANS RV14 G-STRV**  
Electrical Reference Manual

# SECTION 3 - AVIONICS

## GD-40

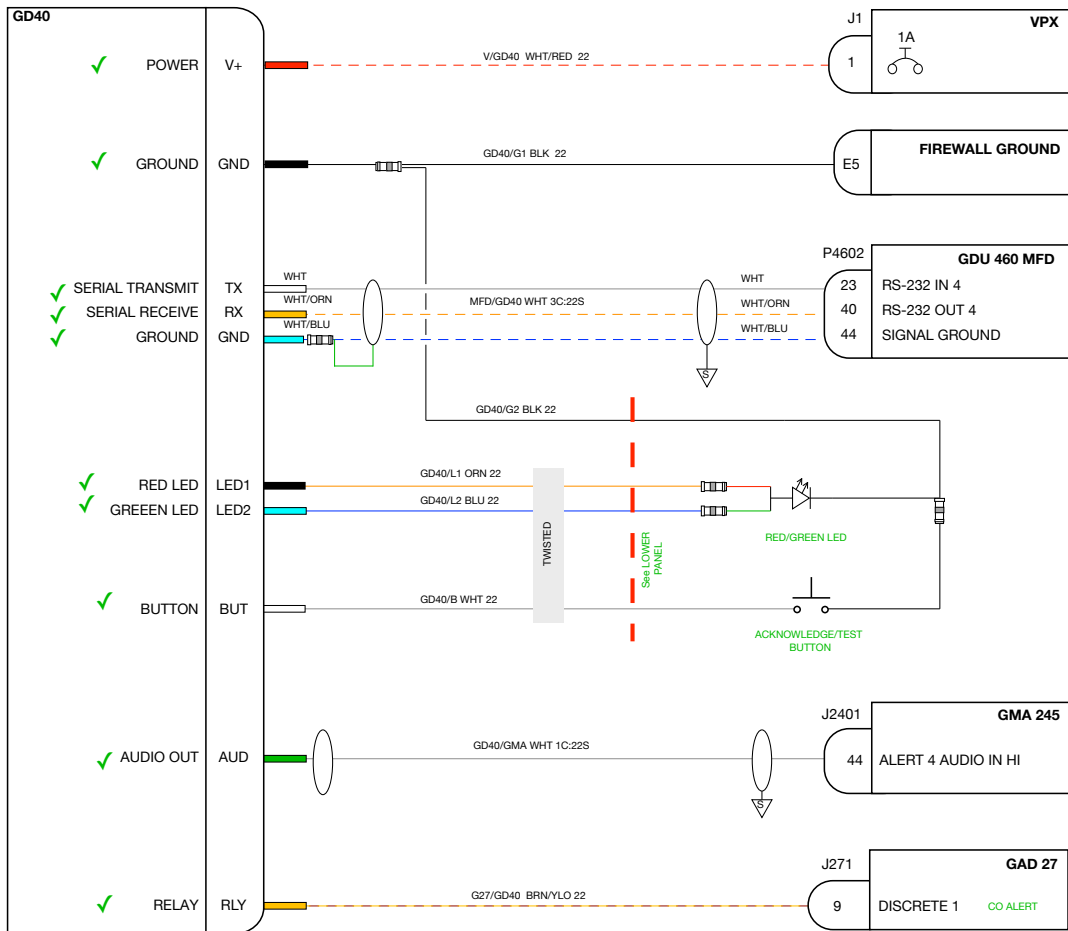

RV14 G-STRV	GD40
Builder:	Steve Hicks
Vans Builder No:	140413
LAA No:	393-15500
Rev:	As Built
Rev Date:	27 Apr 2021



**VANS RV14 G-STRV**  
Electrical Reference Manual

# SECTION 3 - AVIONICS

## GDU 460 MFD

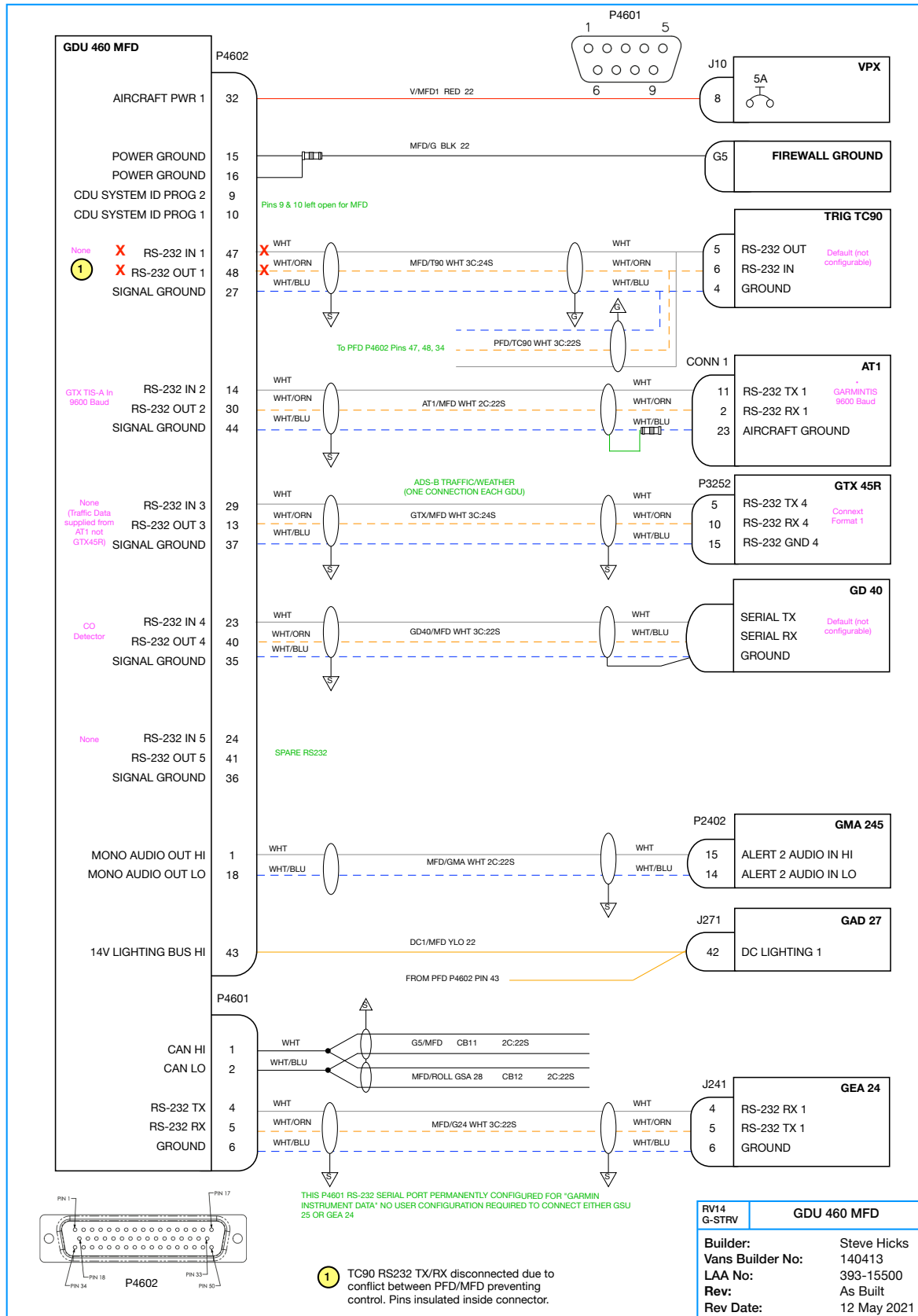



**VANS RV14 G-STRV**  
Electrical Reference Manual

## SECTION 3 - AVIONICS

### GDU 460 PFD P4601

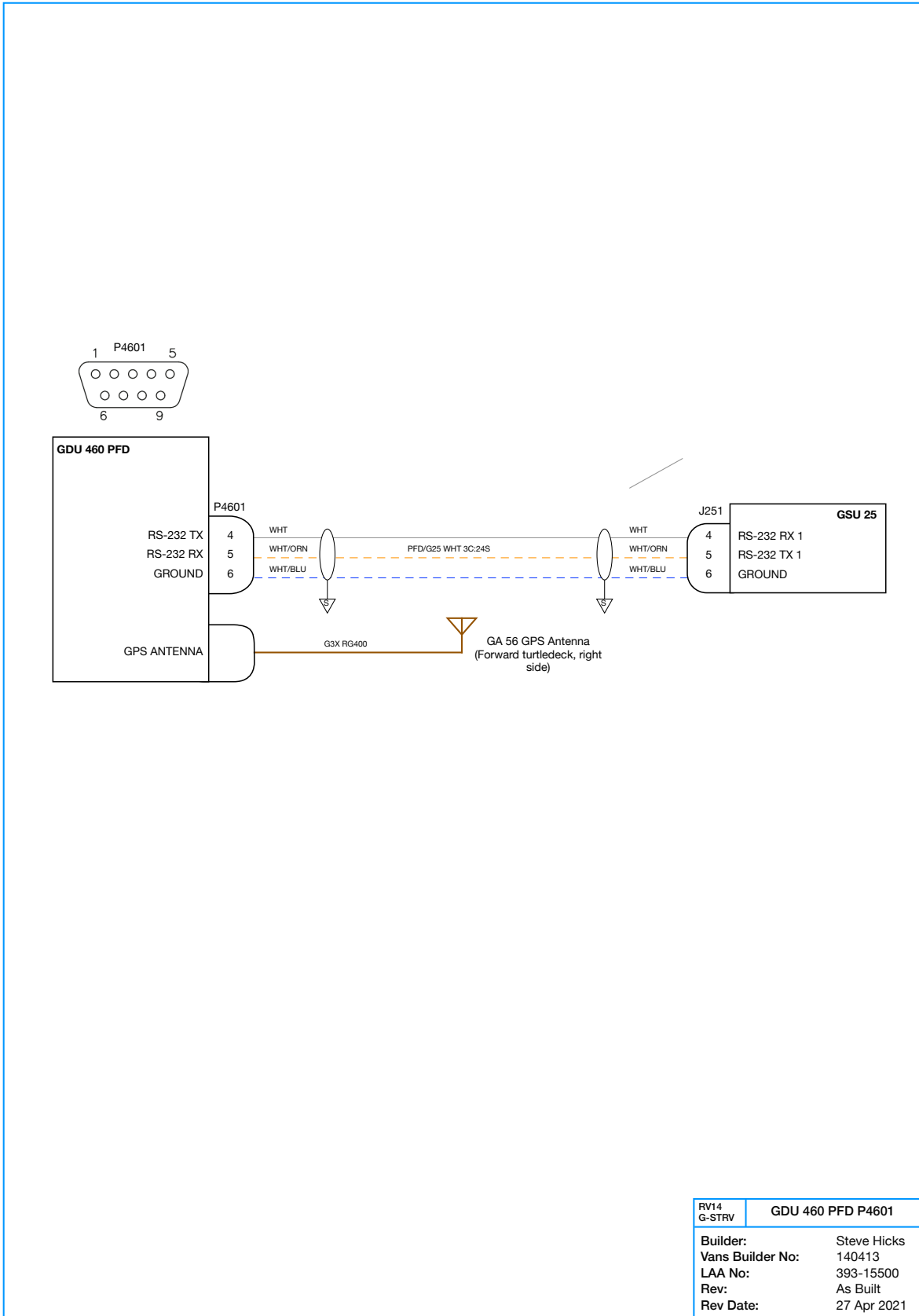



**VANS RV14 G-STRV**  
Electrical Reference Manual

# SECTION 3 - AVIONICS

## GDU 460 PFD P4602

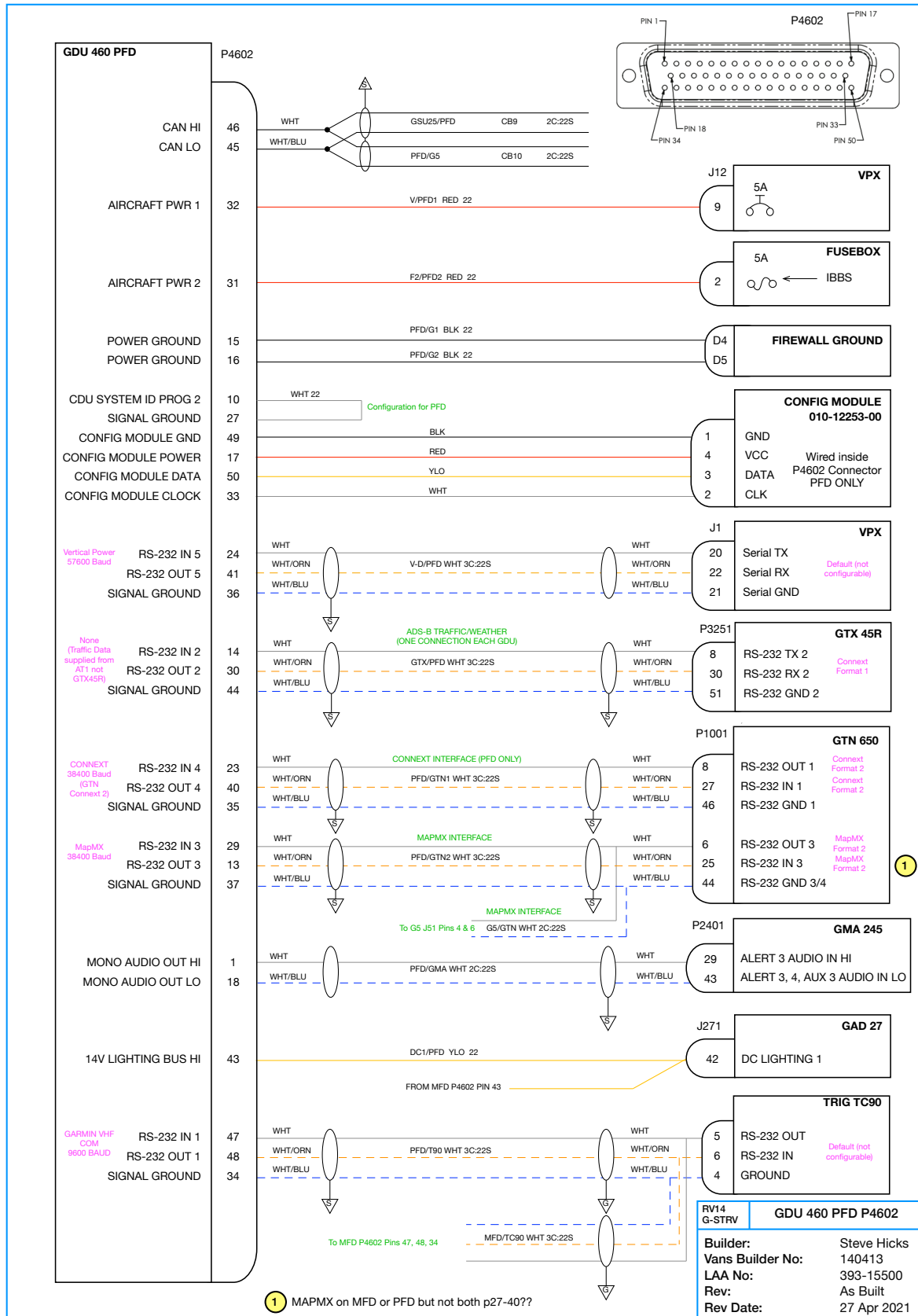



**VANS RV14 G-STRV**  
Electrical Reference Manual

# SECTION 3 - AVIONICS

## GEA 24 J241 and J242

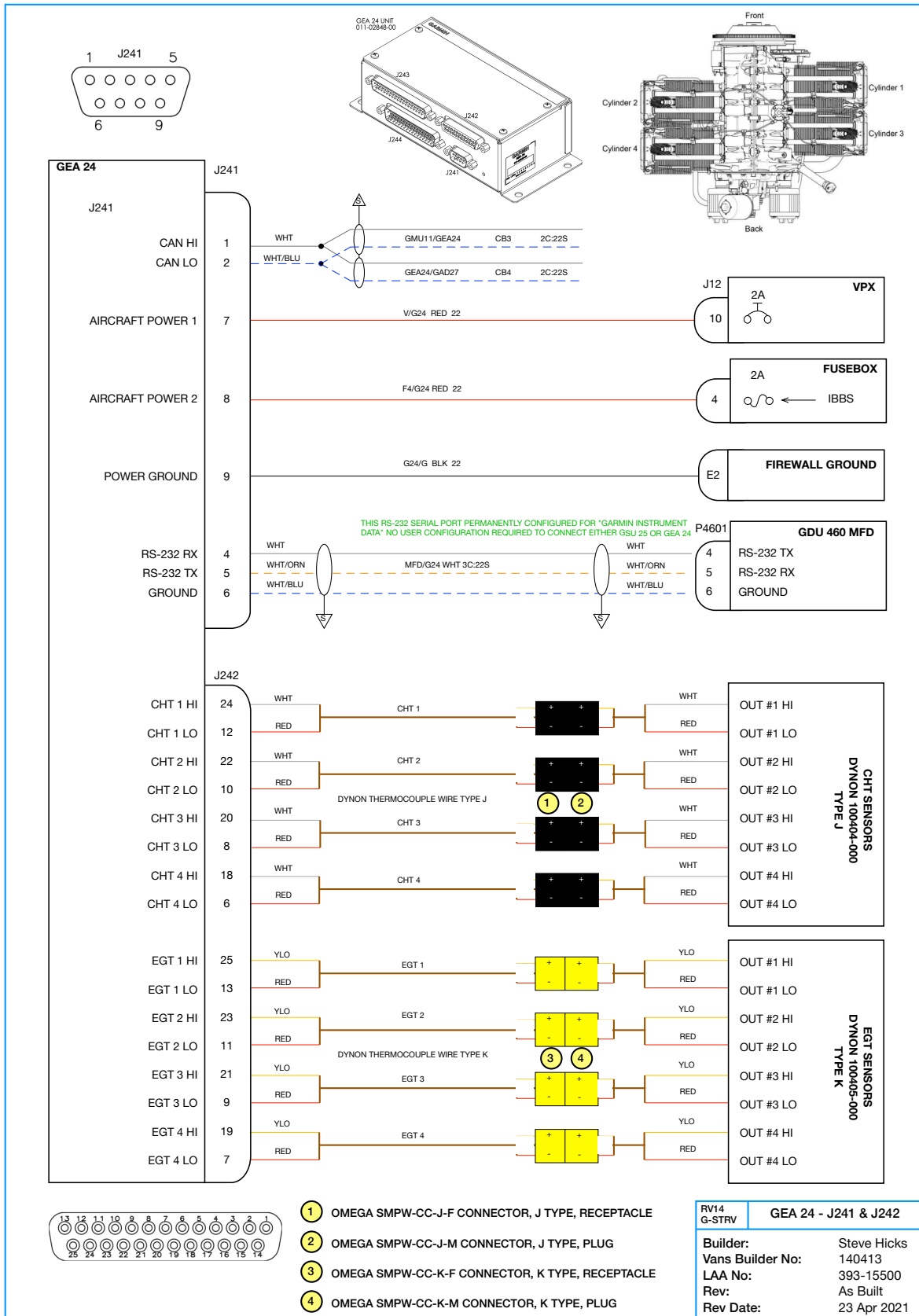



**VANS RV14 G-STRV**  
Electrical Reference Manual

# SECTION 3 - AVIONICS

## GEA 24 J243

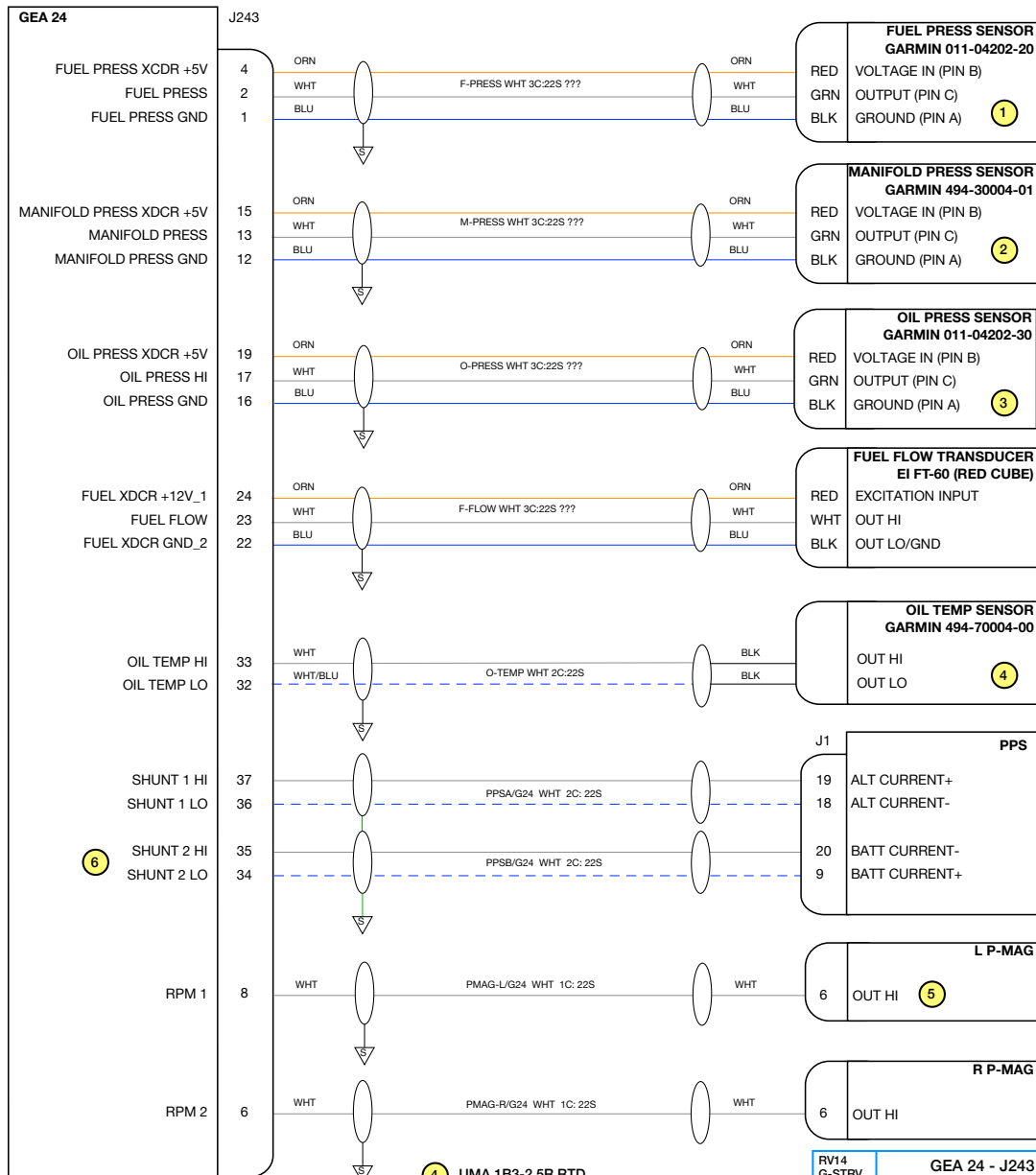
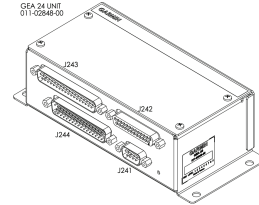
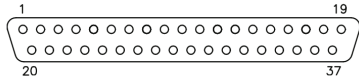

- 1** Kavlico P4055-5020-3
- 2** Kavlico P4055-30A-E4A
- 3** Kavlico P4055-5020-4

- 4** UMA 1B3-2.5R RTD
- 5** Need to check PMag 12V output OK!
- 6** PPS Bat Current+ needs to be connected to GEA24 SHUNT 2 LO for Bat Charge to show as a +ve on G3X, and discharge as a -ve.

RV14 G-STRV	GEA 24 - J243
Builder:	Steve Hicks
Vans Builder No:	140413
LAA No:	393-15500
Rev:	As Built
Rev Date:	22 Aug 2022



**VANS RV14 G-STRV**  
Electrical Reference Manual

# SECTION 3 - AVIONICS

## GEA 24 J244

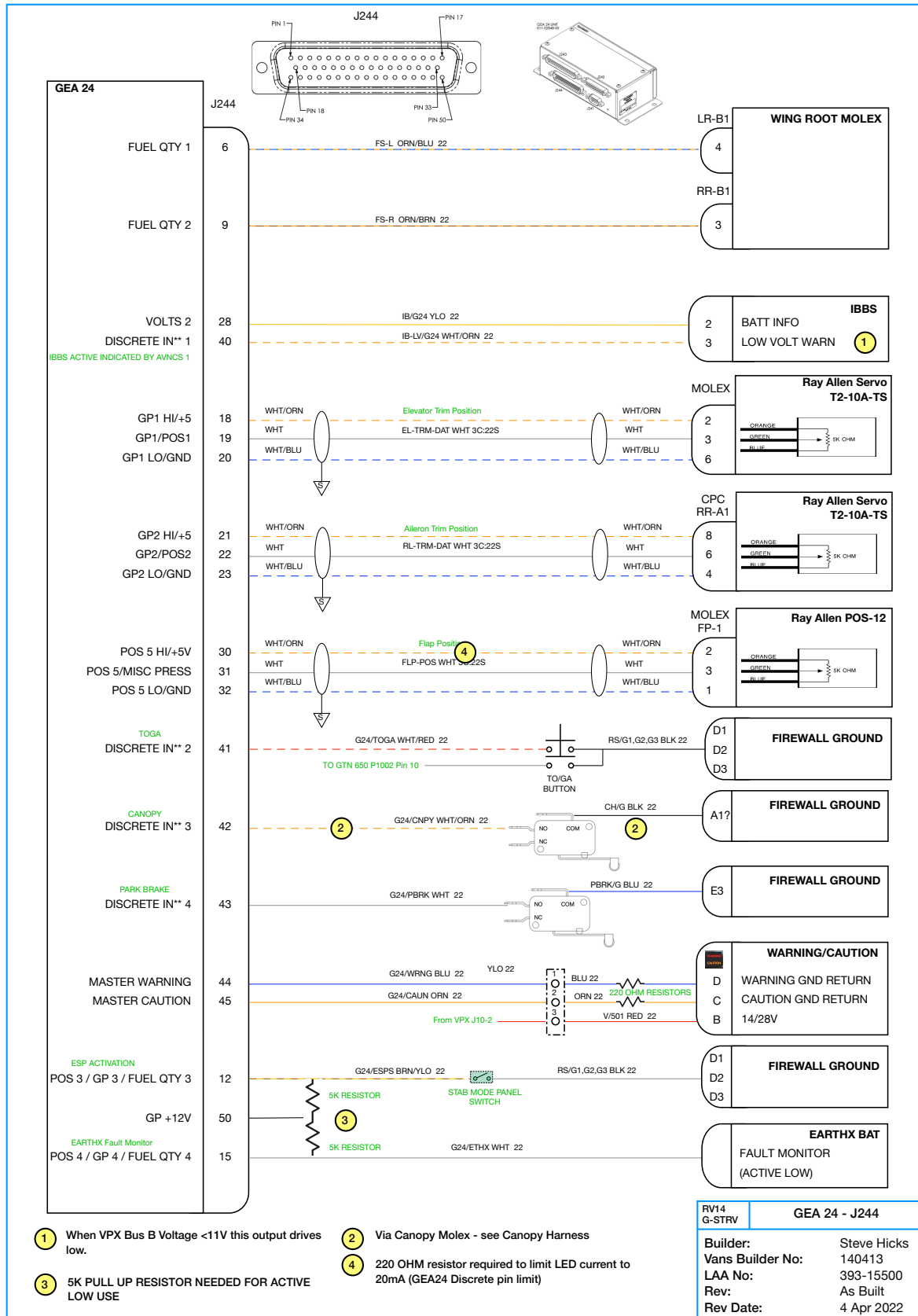



**VANS RV14 G-STRV**  
Electrical Reference Manual

# SECTION 3 - AVIONICS

## GMA 245 J2401

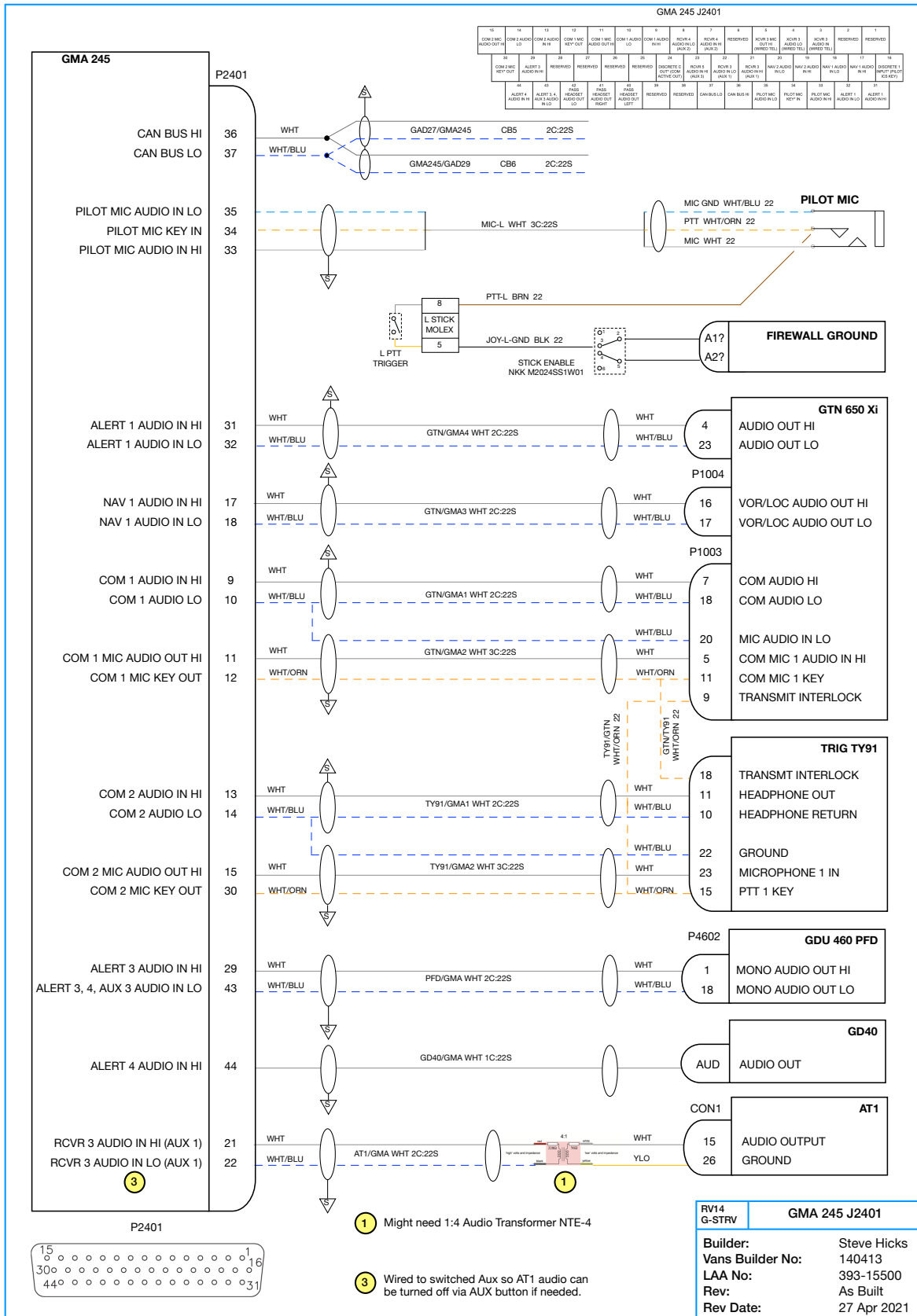



**VANS RV14 G-STRV**  
Electrical Reference Manual

# SECTION 3 - AVIONICS

## GMA 245 J2402

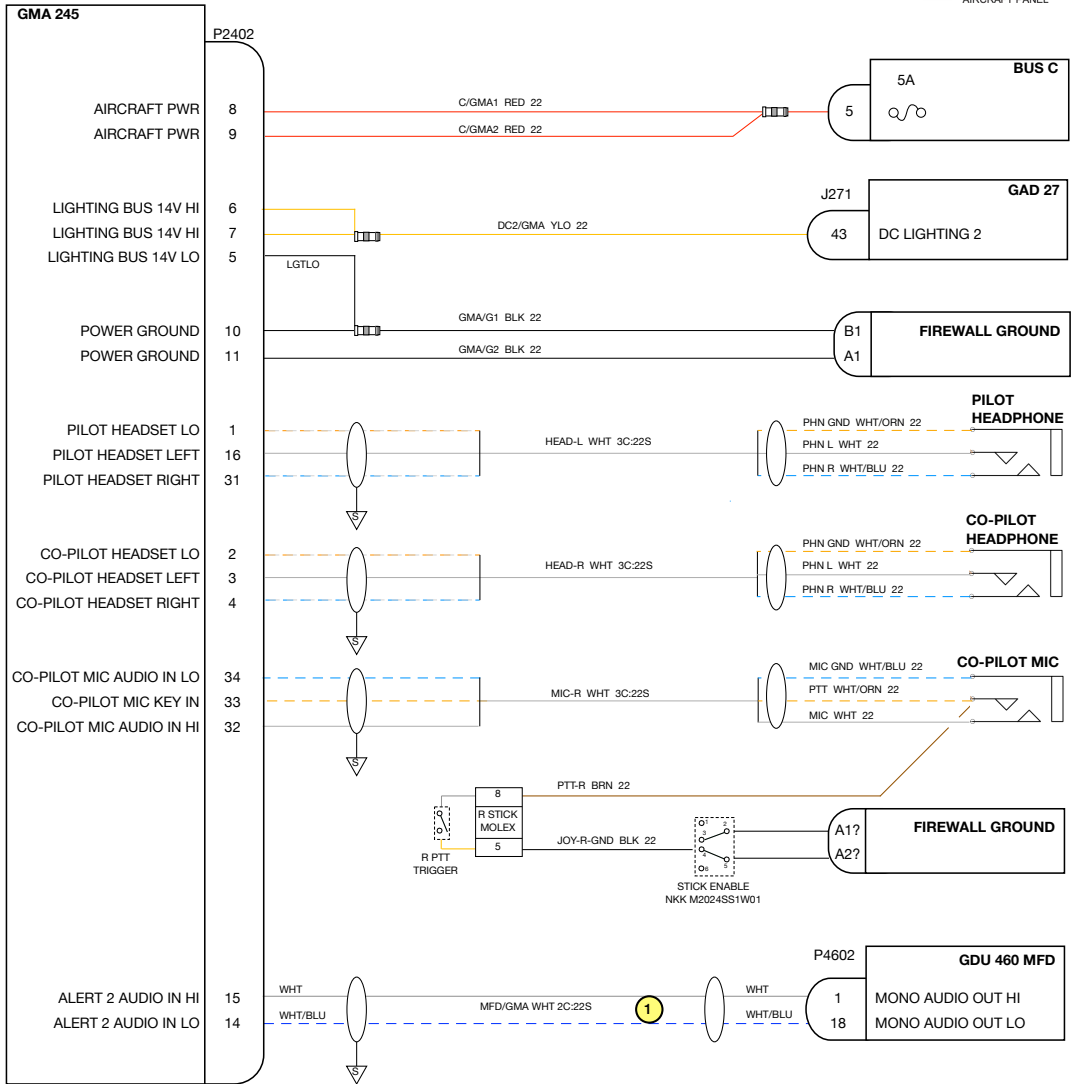
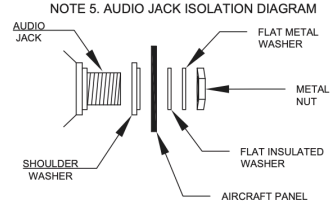
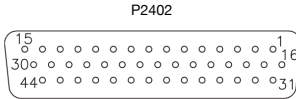

GMA 245 J2402

15	14	13	12	11	10	9	8	7	6	5	4	3	2	1
ALERT 2 AUDIO IN HI	ALERT 2 LO, FALSESAFE AUDIO IN LO	PASS 1 CS KEY	RESERVED	POWER GROUND	POWER GROUND	ARBORANT POWER	ARBORANT POWER	LIGHTING BUS 14V HI28V HI	LIGHTING BUS 14V HI28V HI	LIGHTING BUS 14V LO28V LO	COPILOT HEADSET AUDIO OUT RIGHT	COPILOT HEADSET AUDIO OUT LEFT	COPILOT HEADSET AUDIO OUT LO	PILOT HEADSET AUDIO OUT LEFT
38	29	28	27	26	25	24	23	22	21	20	19	18	17	16
DISCRETE 6 INPUT (COPILOT CS KEY)	FALSESAFE (WARN AUDIO IN HI)	MUSIC 2 IN LO	MUSIC 2 IN RIGHT	MUSIC 2 IN LEFT	MUSIC 1 IN LO	MUSIC 1 IN RIGHT	MUSIC 1 IN LEFT	DISCRETE 5 INPUT (PLAY KEY)	GROUND	DISCRETE 4 INPUT (COM SWAP)	RESERVED	RESERVED	RESERVED	PILOT HEADSET AUDIO OUT RIGHT
44	43	42	41	40	39	38	37	36	35	34	33	32	31	30
SPEAKER AUDIO OUT HI	SPEAKER AUDIO OUT LO	PASS 4 MIC AUDIO IN LO	PASS 4 MIC AUDIO IN HI	PASS 3 MIC AUDIO IN LO	PASS 3 MIC AUDIO IN HI	PASS 2 MIC AUDIO IN LO	PASS 2 MIC AUDIO IN HI	PASS 1 MIC AUDIO IN LO	PASS 1 MIC AUDIO IN HI	COPILOT MIC AUDIO IN LO	COPILOT MIC KEY IN	COPILOT MIC AUDIO IN HI	PILOT HEADSET AUDIO OUT RIGHT	

1 If PFD fails then Alert Audio will be available from MFD ... G3X Manual 35.4.20 Sound Configuration Page

RV14 G-STRV	GMA 245 J2402
Builder:	Steve Hicks
Vans Builder No:	140413
LAA No:	393-15500
Rev:	As Built
Rev Date:	27 Apr 2021



**VANS RV14 G-STRV**  
Electrical Reference Manual

# SECTION 3 - AVIONICS

## GMC 507

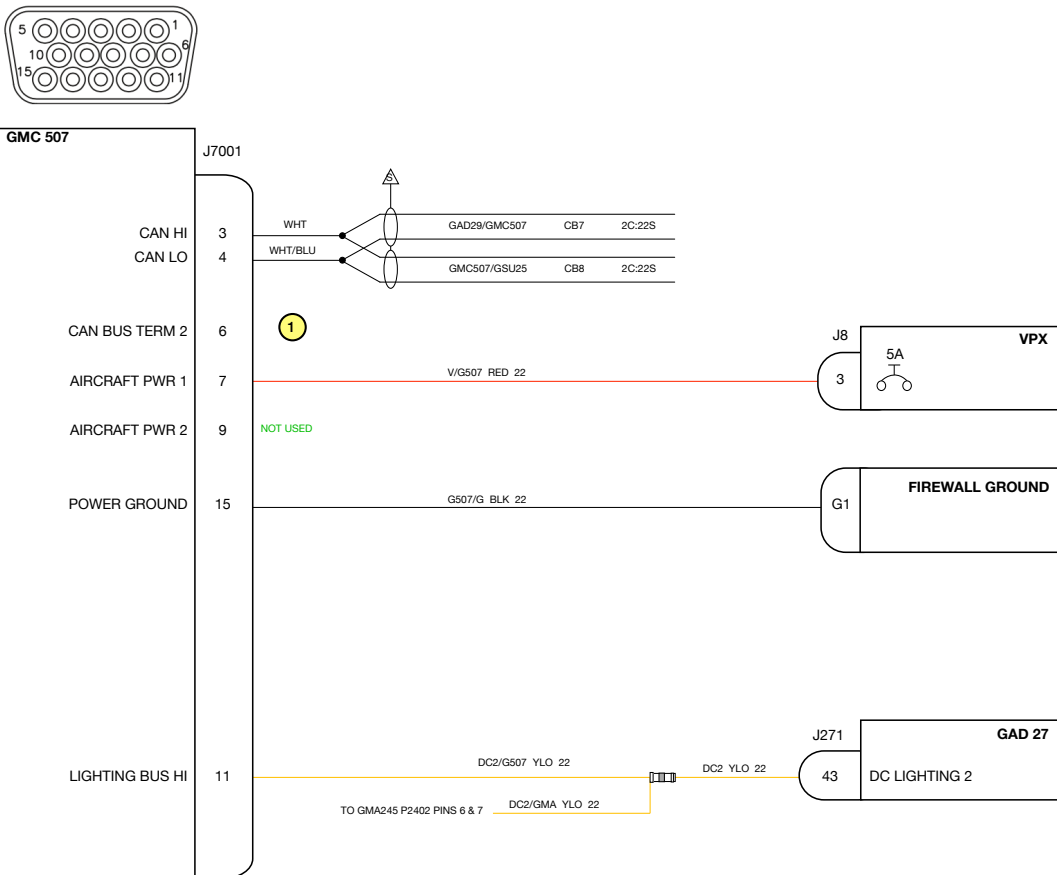

**1** PIN 6 NOTE: INSTALL AN EMPTY PIN 6 IN THE CABLE CONNECTOR TO KEY THIS CONNECTOR AND PREVENT IT FROM BEING INSTALLED UPSIDE DOWN

RV14 G-STRV	GMC 507
Builder:	Steve Hicks
Vans Builder No:	140413
LAA No:	393-15500
Rev:	As Built
Rev Date:	14 Apr 2021



**VANS RV14 G-STRV**  
Electrical Reference Manual

# SECTION 3 - AVIONICS

## GMU 11

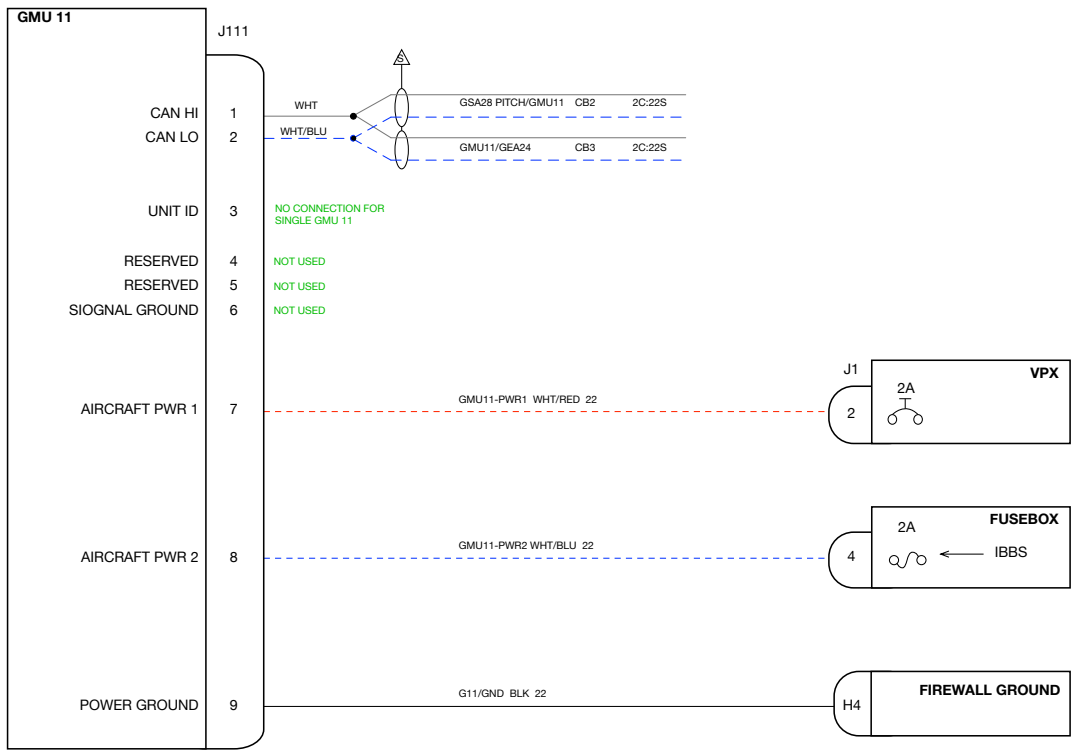
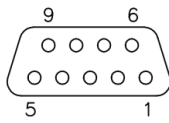

RV14 G-STRV	GMU 11
Builder:	Steve Hicks
Vans Builder No:	140413
LAA No:	393-15500
Rev:	As Built
Rev Date:	27 Apr 2021



**VANS RV14 G-STRV**  
Electrical Reference Manual

# SECTION 3 - AVIONICS

## GSU 25

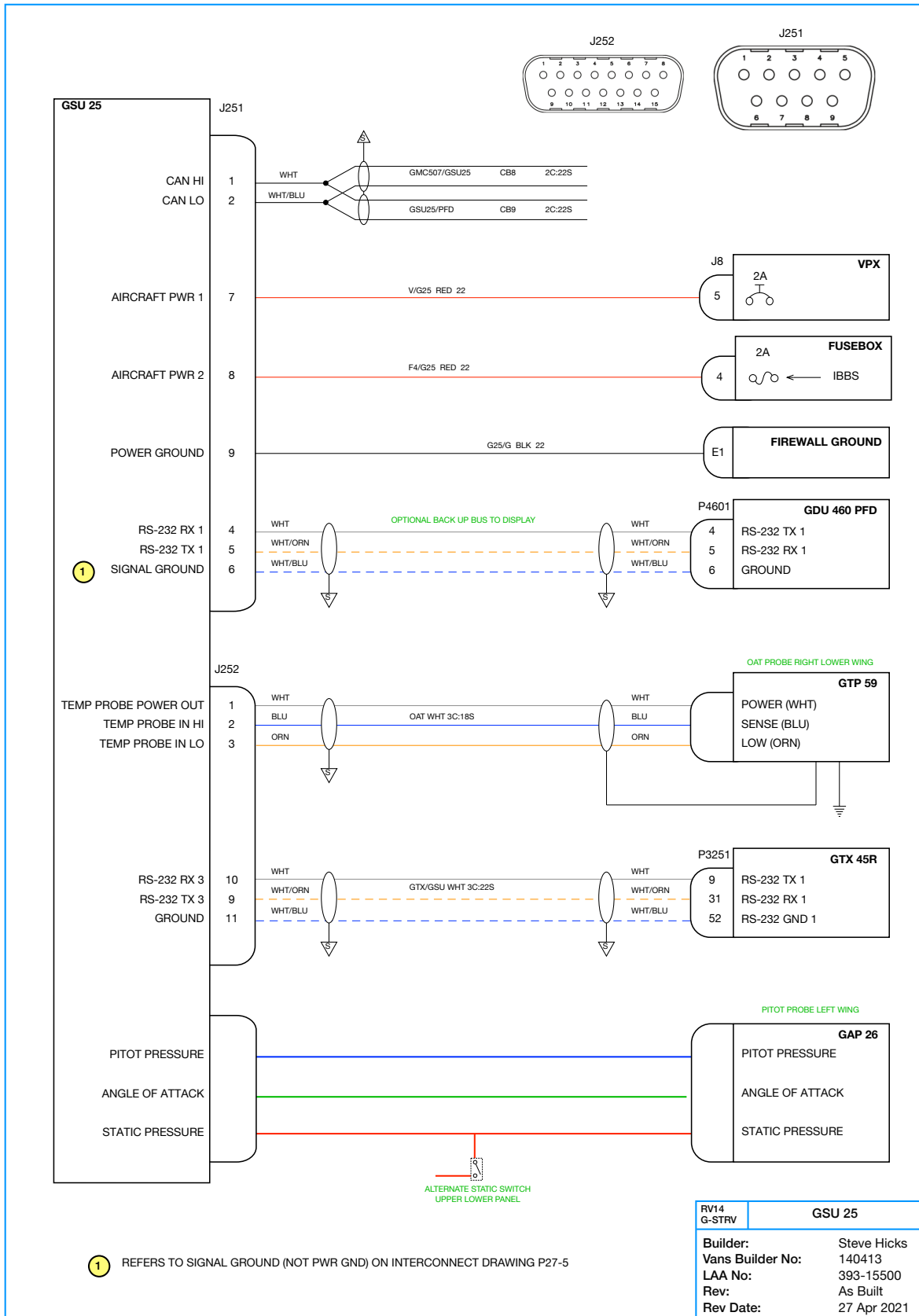



**VANS RV14 G-STRV**  
Electrical Reference Manual

# SECTION 3 - AVIONICS

## GTN 650Xi P1001

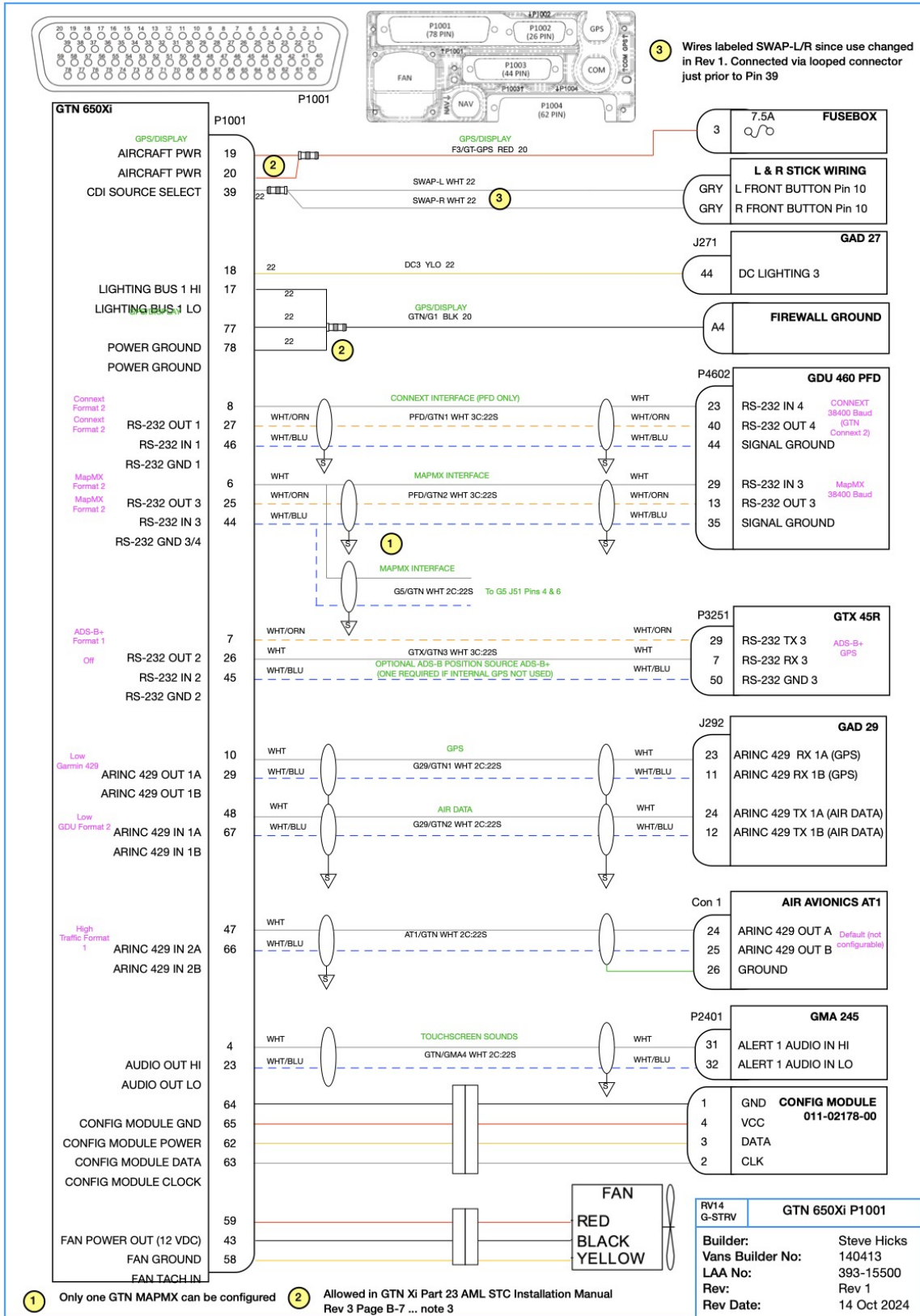



**VANS RV14 G-STRV**  
Electrical Reference Manual

# SECTION 3 - AVIONICS

## GTN 650Xi P1002 and P1003

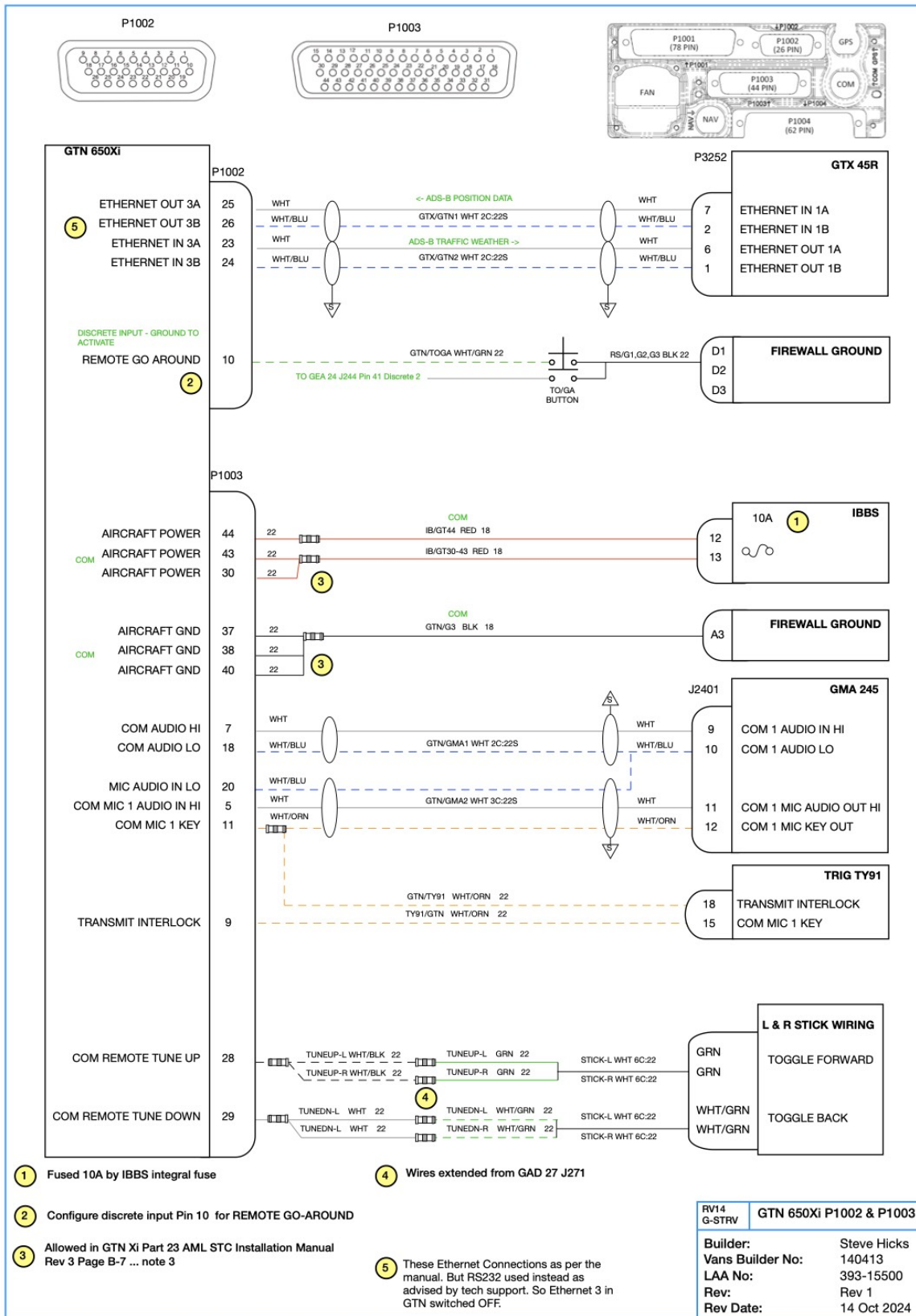



**VANS RV14 G-STRV**  
Electrical Reference Manual

# SECTION 3 - AVIONICS

## GTN 650Xi P1004

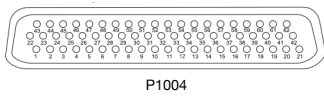

P1004

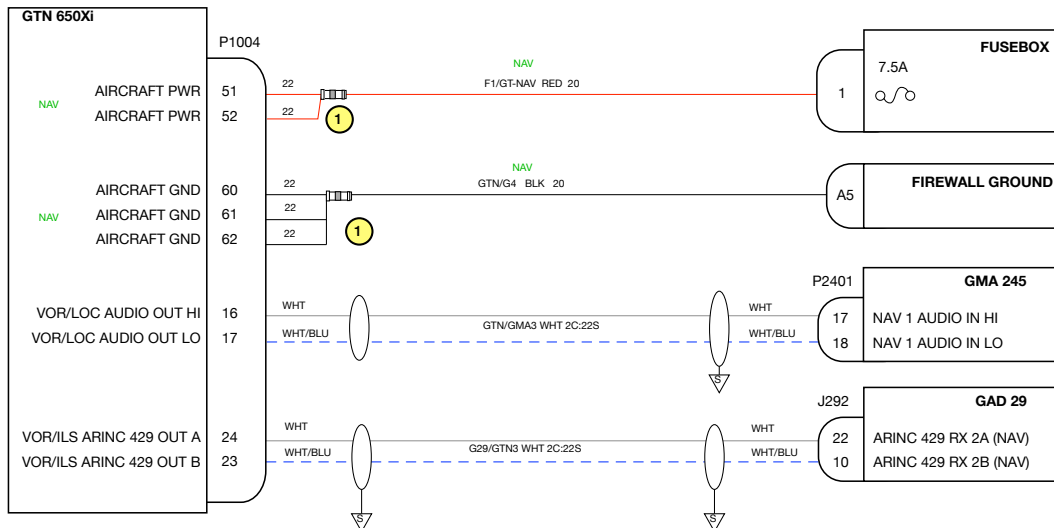
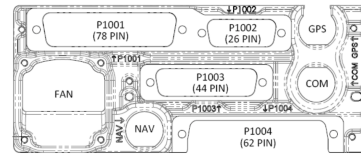

① Allowed in GTN Xi Part 23 AML STC Installation Manual  
Rev 3 Page B-7 ... note 3

RV14 G-STRV	GTN 650Xi P1004
Builder:	Steve Hicks
Vans Builder No:	140413
LAA No:	393-15500
Rev:	As Built
Rev Date:	27 Apr 2021





**VANS RV14 G-STRV**  
Electrical Reference Manual

# SECTION 3 - AVIONICS

## TRIG TY91 and TC90

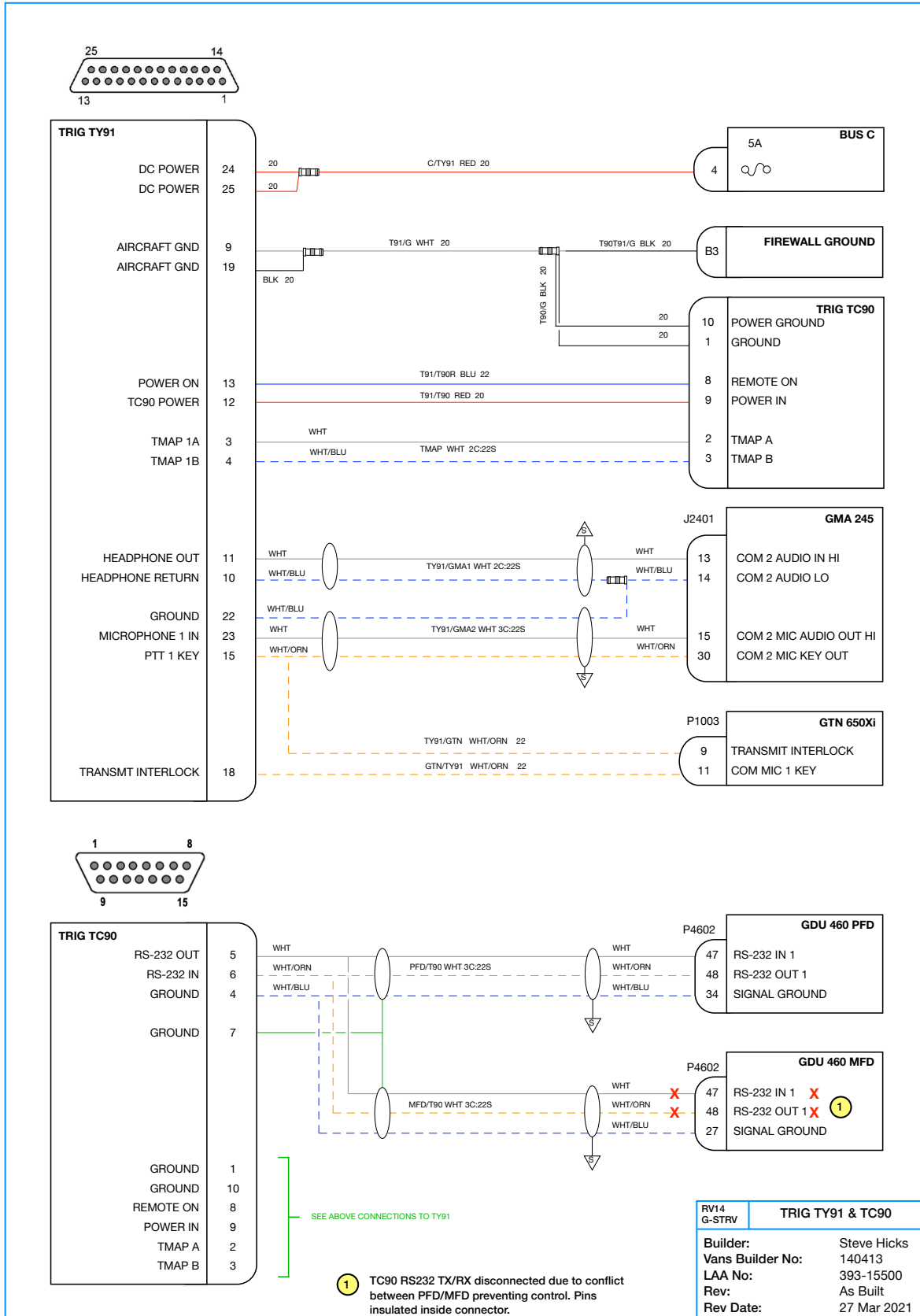



**VANS RV14 G-STRV**  
Electrical Reference Manual

# SECTION 3 - AVIONICS

## PMags

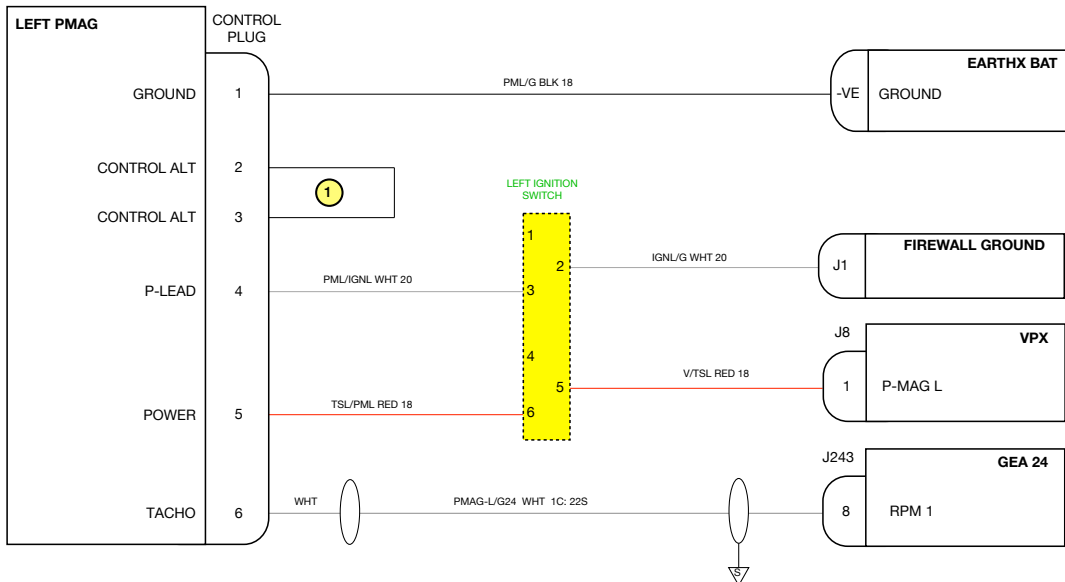
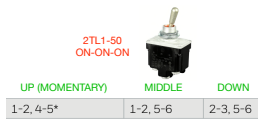
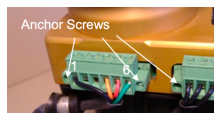
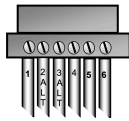
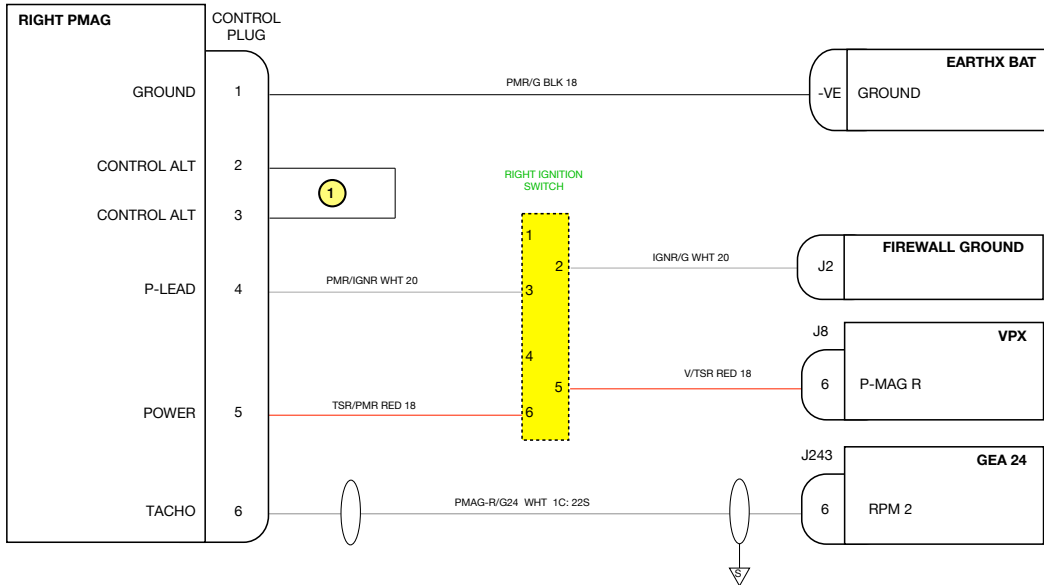

1 Jumper across 2 & 3 for timing curve "A"

RV14 G-STRV	PMags
Builder:	Steve Hicks
Vans Builder No:	140413
LAA No:	393-15500
Rev:	As Built
Rev Date:	8 May 2022



# SECTION 3 - AVIONICS

## Standby Trim Overview

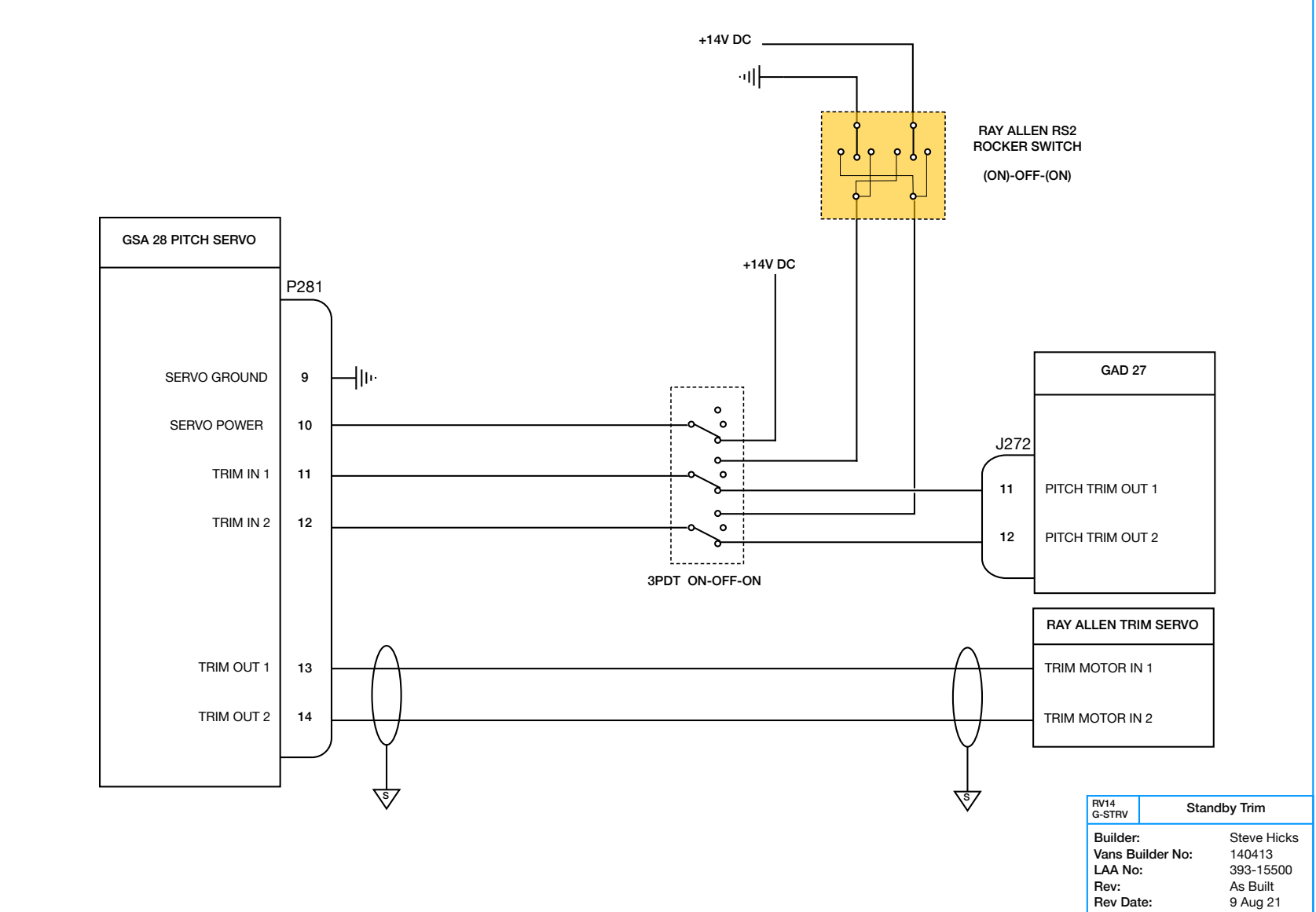

RV14 G-STRV	Standby Trim
Builder:	Steve Hicks
Vans Builder No:	140413
LAA No:	393-15500
Rev:	As Built
Rev Date:	9 Aug 21